



North America Collection





**Light is design.**



# Index

Acorn <b>7</b>	Enoki <b>45</b>	Narciso <b>87</b>
Aprile <b>11</b>	Feel <b>49</b>	New Classic <b>93</b>
C'hi <b>15</b>	Glo <b>53</b>	Pop <b>99</b>
China <b>23</b>	Jeï Jeï <b>61</b>	Storm <b>103</b>
Clash <b>29</b>	Je Suis <b>67</b>	Wonder <b>107</b>
Clip <b>33</b>	Mamì <b>71</b>	Woody <b>111</b>
Elisabeth <b>37</b>	MoM <b>81</b>	Plates & canopies <b>115</b>



2017

# ACORN

Matteo Bianchi

Suspension with structure in concrete and shade in frosted or transparent glass.  
Protection IP65 against water from any direction.

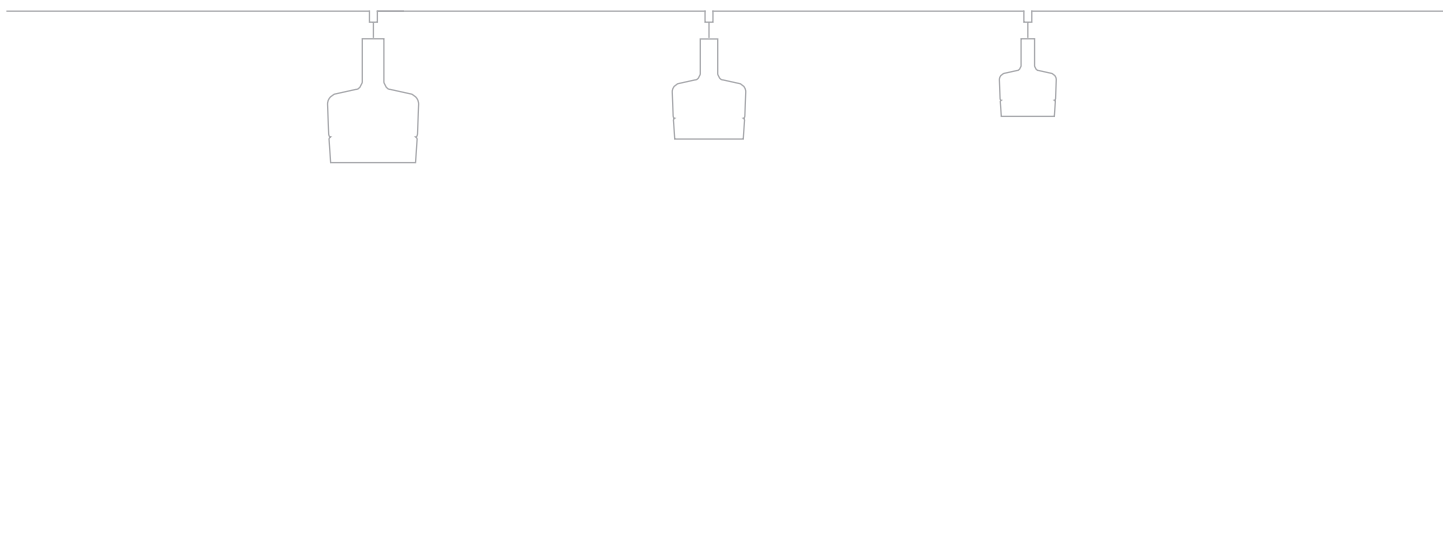





# Acorn

## SUSPENSION

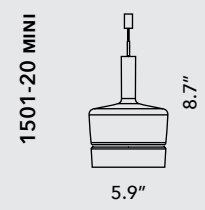
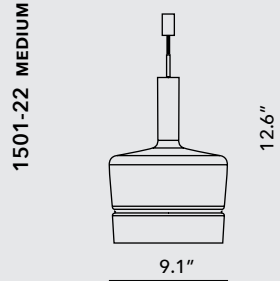
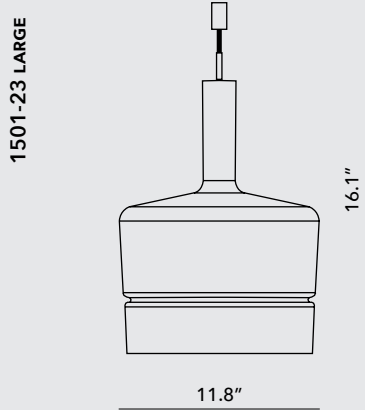

## LIGHT SOURCE

1501-23  
20W - LED 3000K\* 1700 lm Dimm. TRIAC

1501-22  
15W - LED 3000K\* 1300 lm Dimm. TRIAC

1501-20  
8W - LED 3000K\* 650 lm Dimm. TRIAC

## NOTE

Standard cable length 78.7"

## GLASS FINISHES

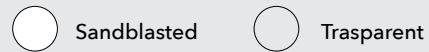

## STRUCTURE FINISHES

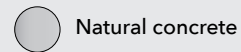

## CANOPY FINISHES

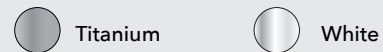







2017

# APRILE

Nicola Gallizia

Wall lamp with metal structure in the finishes: glossy inox steel, brushed bronze or white varnished.





# Aprile

## WALL LAMP

---

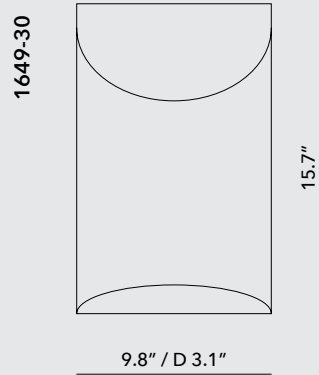

### LIGHT SOURCE

---

1649-30

For light source information please refer to [www.pentalight.com](http://www.pentalight.com)

### NOTE

---

ADA

### STRUCTURE FINISHES

---

 White

 Brushed bronze

 Glossy inox steel



1999

# C'HI

Umberto Asnago

Lamps with structure in nickel satin metal. Outer shade in blown glass in the following colours:  
silver, transparent, opal white or sand. Inner shade in mat glass.

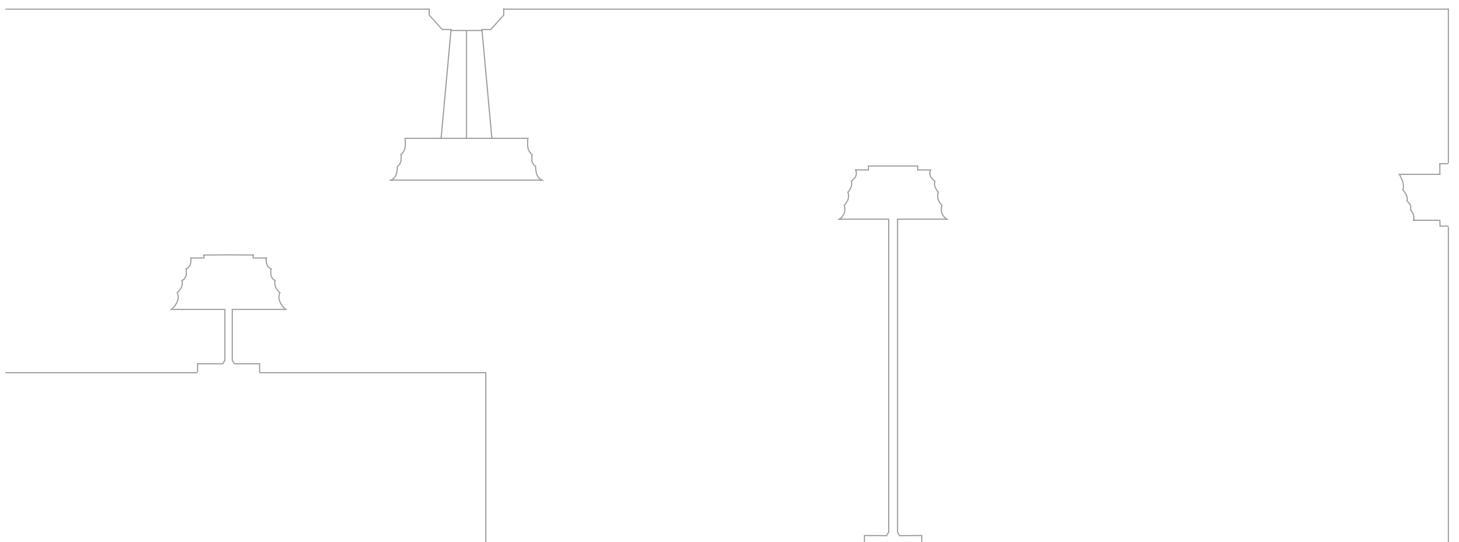





# C'hi

## SUSPENSION

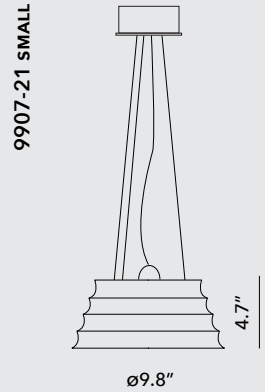
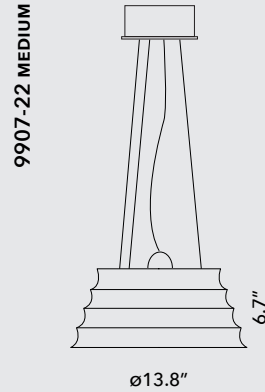
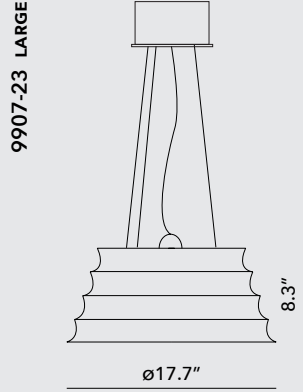
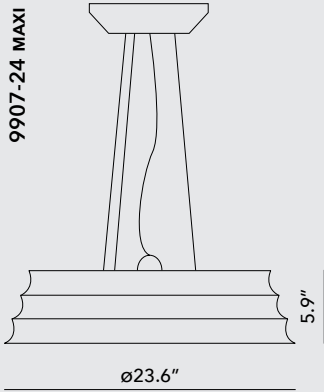

## LIGHT SOURCE

### 9907-24

3x 10W - E26\* LED / 3x max 100W - E26 Halo\*

### 9907-23

1x 10W - E26\* LED / 1x max 100W - E26 Halo\*

### 9907-22

1x 10W - E26\* LED / 1x max 100W - E26 Halo\*

### 9907-21

1x 5W - E12\* LED / 1x max 60W - E12 Halo\*

## NOTE

Silver glass is not available for the maxi suspension.

Standard cable length 78.7"

## GLASS FINISHES

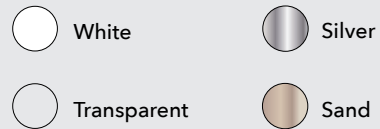

## STRUCTURE FINISHES



## CANOPY FINISHES

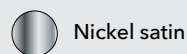





# C'hi

## TABLE LAMP

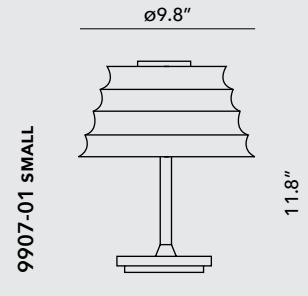
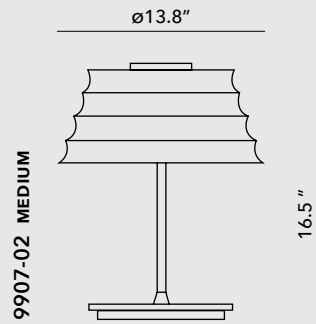
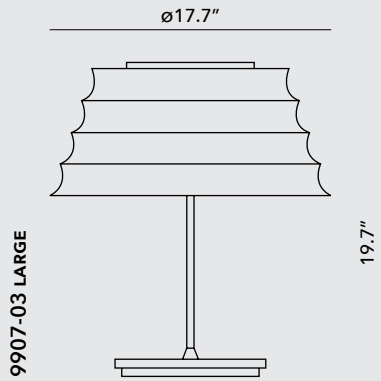

### LIGHT SOURCE

#### 9907-03

1x 10W - E26\* LED / 1x max 100W - E26 Halo\*

#### 9907-02

1x 10W - E26\* LED / 1x max 100W - E26 Halo\*

#### 9907-01

1x 5W - E12\* LED / 1x max 60W - E12 Halo\*

### GLASS FINISHES



White



Silver



Transparent



Sand

### STRUCTURE FINISHES



Nickel satin

### CANOPY FINISHES



Nickel satin



# C'hi

## FLOOR AND WALL LAMP

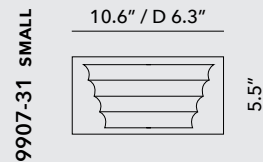
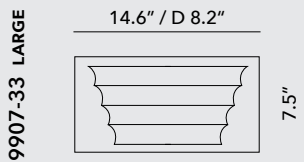
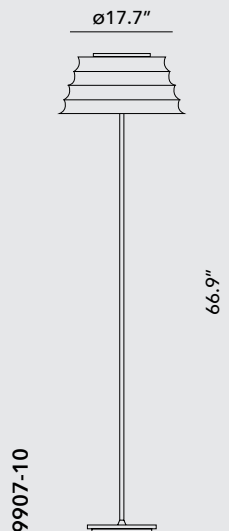

### LIGHT SOURCE - FLOOR LAMP

9907-10

1x max 150W - E26 Halo

### LIGHT SOURCE - WALL LAMPS

9907-33

1x16W LED R7s 117 mm - 1x max 150W R7s 117 mm Halo

9907-31

1x16W LED R7s 117 mm - 1x max 150W R7s 117 mm Halo

### GLASS FINISHES

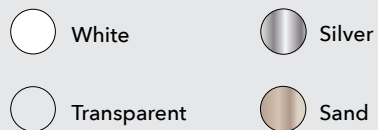

### STRUCTURE FINISHES

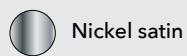



2007

# CHINA

Nicola Gallizia

Lamps with metal structure. Matt varnished in the colours: red, maron glacé, graphite, bronze, rose gold and gold. Glossy varnished in the colours: white or chrome.







# China

## TABLE LAMP

---

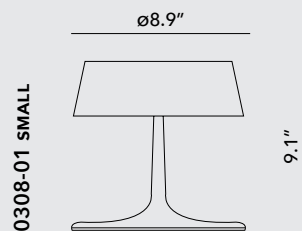
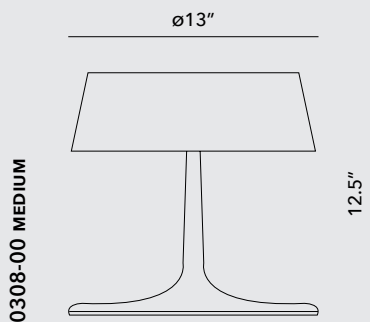

### LIGHT SOURCE

---

#### 0308-00

3x max 40W - E12 Halo

#### 0308-01

2x max 5W - E12 LED / 3x max 40W - E12 Halo

### STRUCTURE FINISHES

---

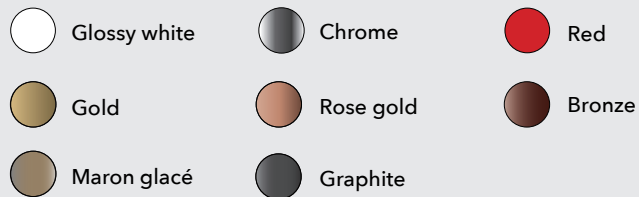





# China

## FLOOR LAMP

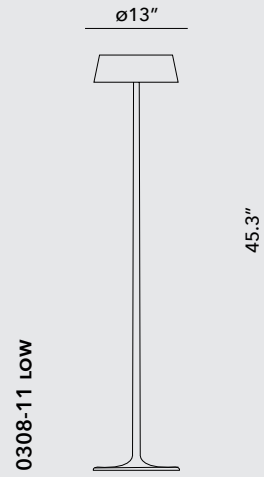
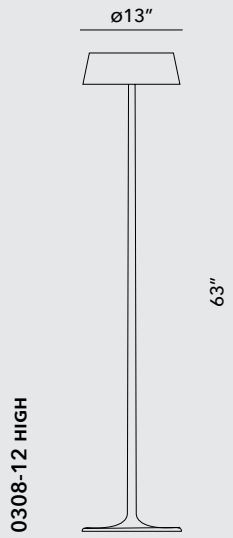

### LIGHT SOURCE

0308-12

3x max 40W - E12 Halo

0308-11

3x max 40W - E12 Halo

### STRUCTURE FINISHES





2017

# CLASH

Artefatto

Wall lamp with inner structure in metal in the finishes graphite or antique brass and outer structure in transparent or fumé glass.





# Clash

## WALL LAMP

---

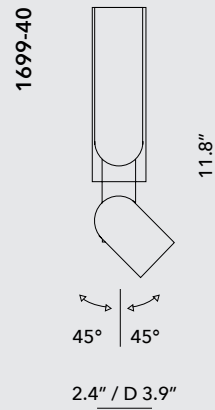
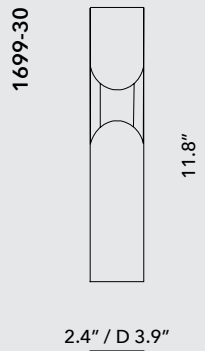

### LIGHT SOURCE

---

1699-30

2x 7W - GU10 LED 2x 600 lm

1699-40

2x 7W - GU10 LED 2x 600 lm

### NOTE

---

ADA

### GLASS FINISHES

---



Transparent



Fumè

### STRUCTURE FINISHES

---



Graphite



Antique brass





2017

# CLIP

Daniel Debiasi & Federico Sandri

Suspension lamps with metal structure in glossy or brushed finishes: gold, rose gold and graphite. Available with open or closed ring, in two sizes, large or mini. Single canopy in the same finishes of the structure. Available as single element or in cluster.

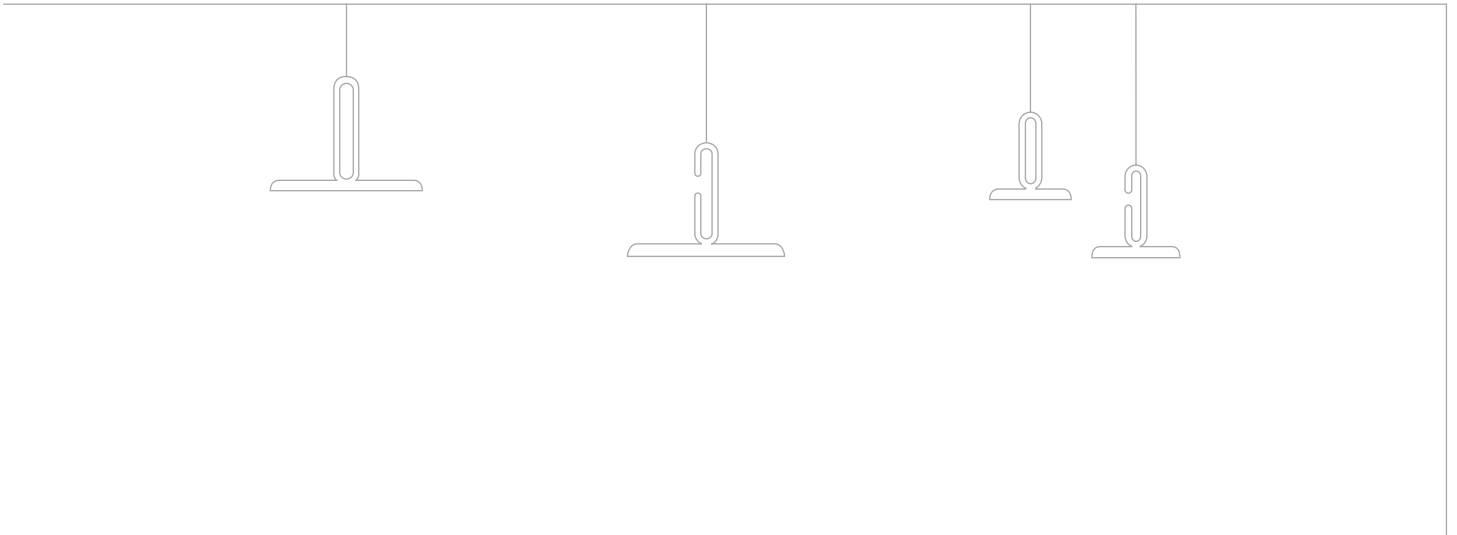





# Clip

## SUSPENSION

---

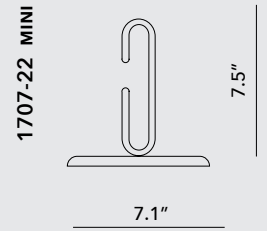
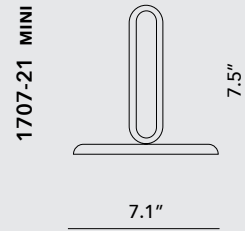
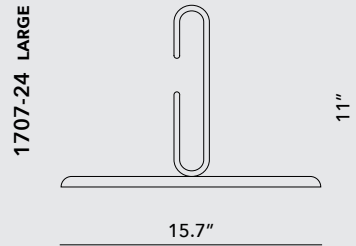
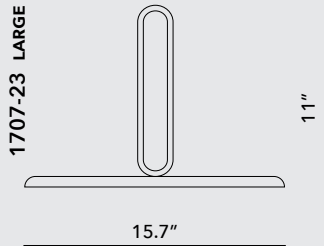

## LIGHT SOURCE

---

### 1702-24

30W LED - 24V 3000 K 2100 lm

### 1702-23

30W LED - 24V 3000 K 2100 lm

### 1702-22

14W LED - 24V 3000 K 1000 lm

### 1702-21

14W LED - 24V 3000 K 1000 lm

## NOTE

---

Standard cable length 78.7"

## STRUCTURE FINISHES

---

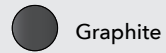



2017

# ELISABETH

Carlo Colombo

Lamps with structure in glossy black nickel. Floor lamp with base in Portoro black marble.  
Table lamp available with base in Carrara white marble or in metal.

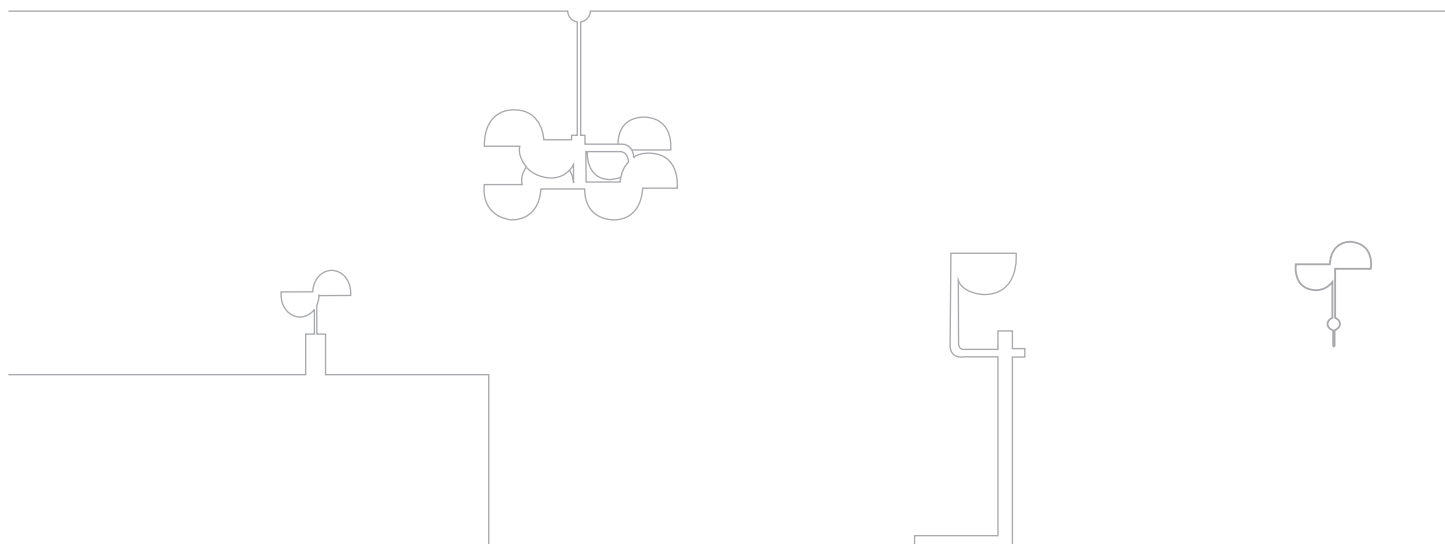



# Elisabeth

## SUSPENSION

1711-23 LARGE

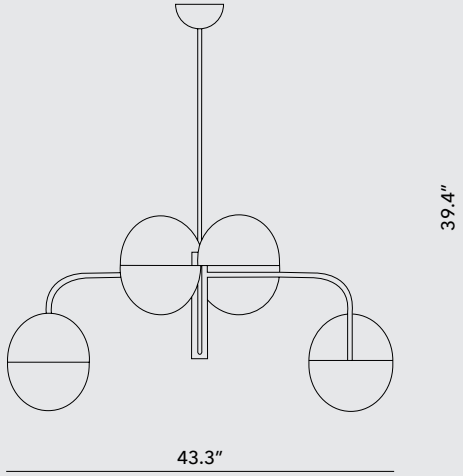

1711-21 SMALL

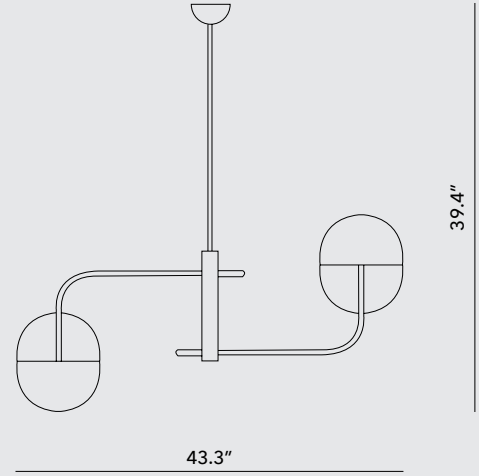

## LIGHT SOURCE

1711-23

8x 10W - LED 3000 K (double lighting) 8x 800 lm

1711-21

4x 10W - LED 3000 K 4x 800 lm

## STRUCTURE FINISHES

 Glossy black





# Elisabeth

## TABLE LAMP

---

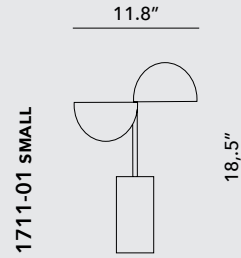
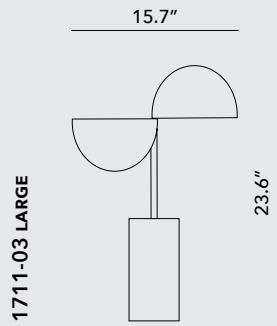

## LIGHT SOURCE

---

1711-03

2x 8W - LED 3000 K 2x650 lm

1711-01

2x 6W - LED 3000 K 2x450 lm

## STRUCTURE FINISHES

---

 Glossy black



# Elisabeth

## FLOOR AND WALL LAMP

---

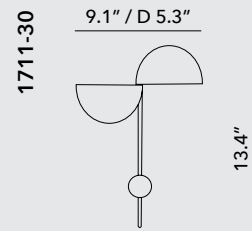
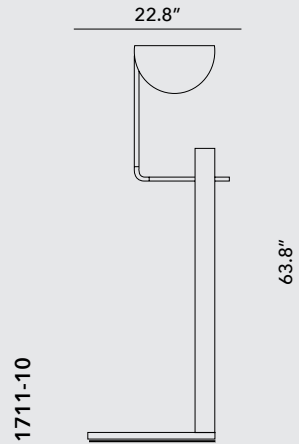

### LIGHT SOURCE - FLOOR LAMP

---

1711-10

30W - LED 3000 K 2500 lm

### LIGHT SOURCE - WALL LAMP

---

1711-30

2x 6W - LED 3000 K 2x 450 lm

### STRUCTURE FINISHES

---

 Glossy black







2017

# ENOKI

Daniel Debiasi & Federico Sandri

Wall lamp in the varnished finishes: white, sand, graphite, gold and rose gold.

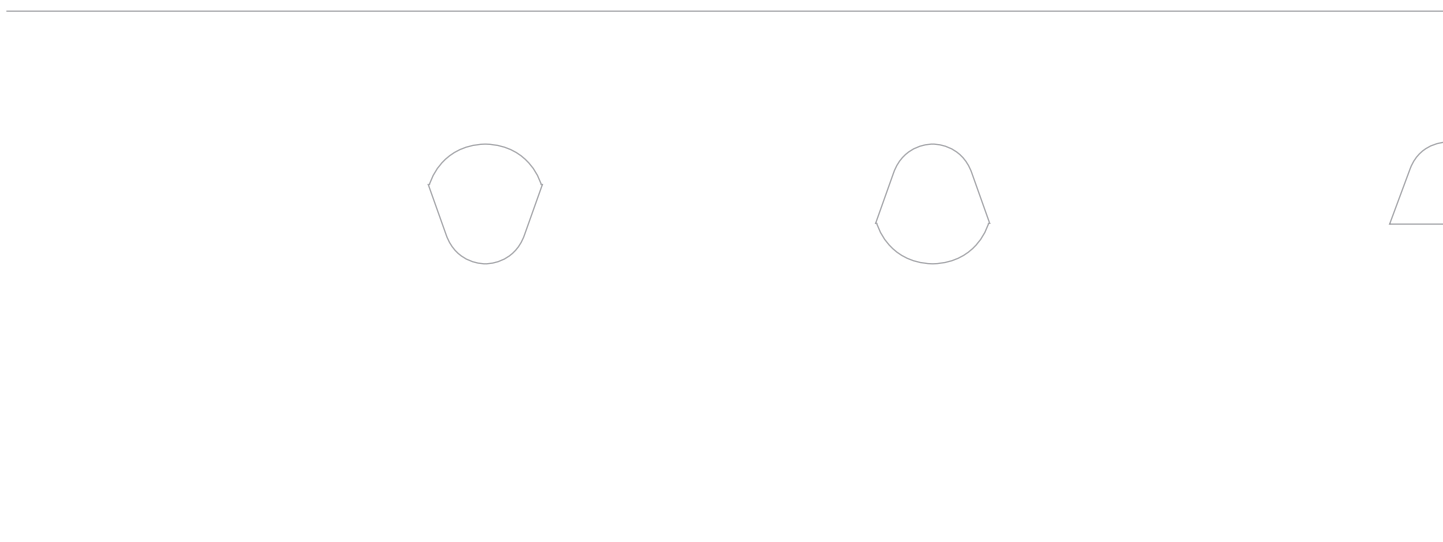



# Enoki

WALL LAMP

---

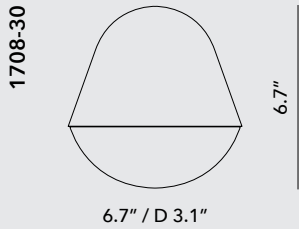

---

**LIGHT SOURCE**

1708-30  
10W - LED 3000 K 800 lm - Dimm. TRIAC

---

**NOTE**

ADA

---

**STRUCTURE FINISHES**

- Graphite
- Gold
- Rose gold
- White
- Sand



2018

# FEEL

Sara Moroni

Modular suspension with metal structure in three sizes available graphite, gold and pink gold matt finishes. Sound-absorbing fabric discs are available in three diameters with the following colors: bordeaux, brick, dark green, dark blue, light gre, petroleum and sand. Discs are also available as a single decorative element, without light.

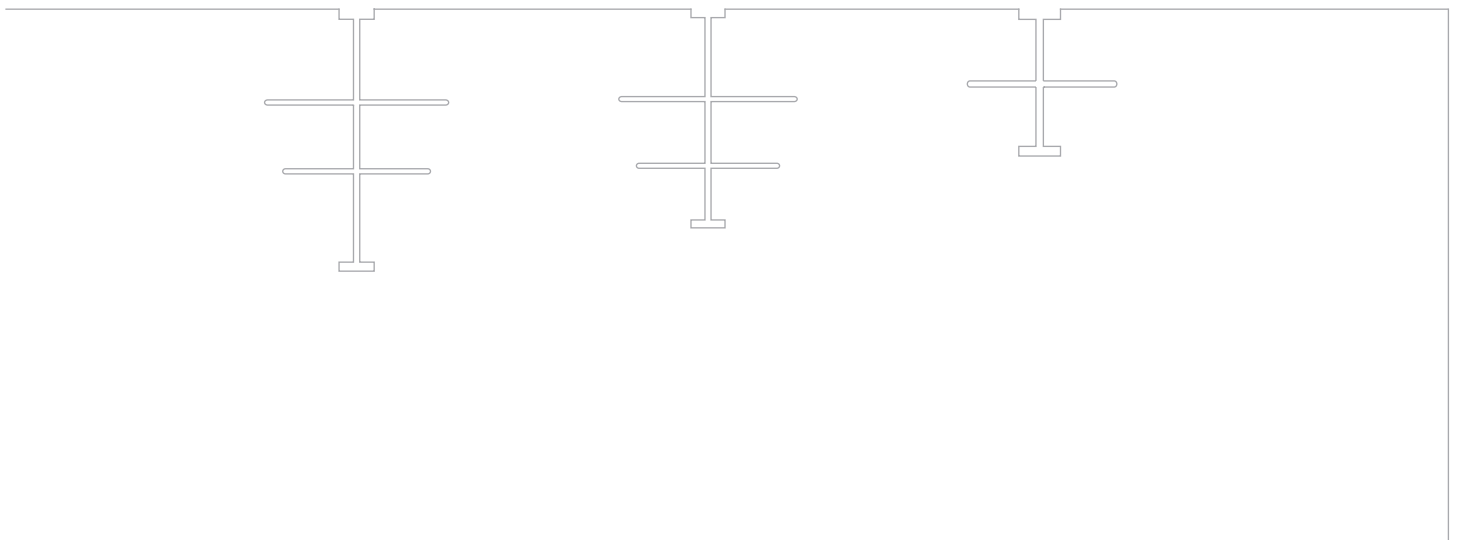





# Feel

## SUSPENSION

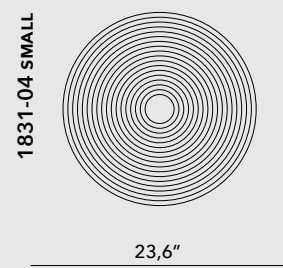
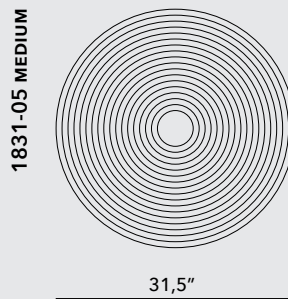
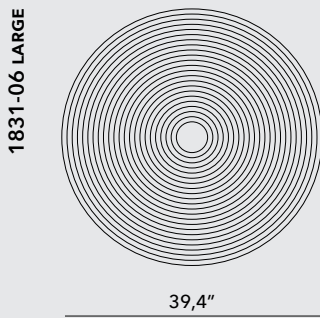
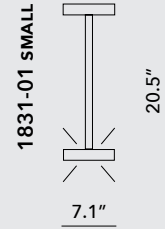
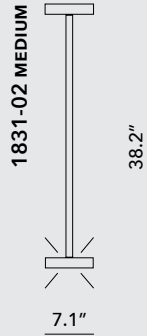

## LIGHT SOURCE

1831-03

Led 27W 3000K 5280 lm

1831-02

Led 27W 3000K 5280 lm

1831-01

Led 27W 3000K 5280 lm

## FABRIC FINISHES

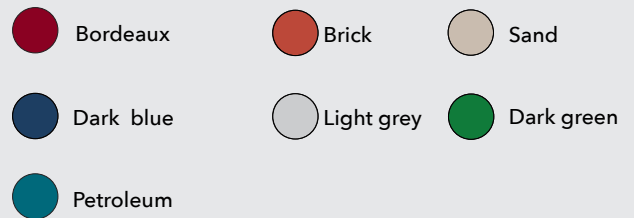

## STRUCTURE FINISHES







2009

# GLO

Carlo Colombo

Lamps with chromed metal structure and borosilicate glass.  
Outer shade available in the finishes: gold, rose gold, silver, black, iridescent, white, 4ever,  
blue, green, violet and transparent.  
Inner shade sandblasted.  
Available as table lamp, floor lamp, suspension and wall lamp.

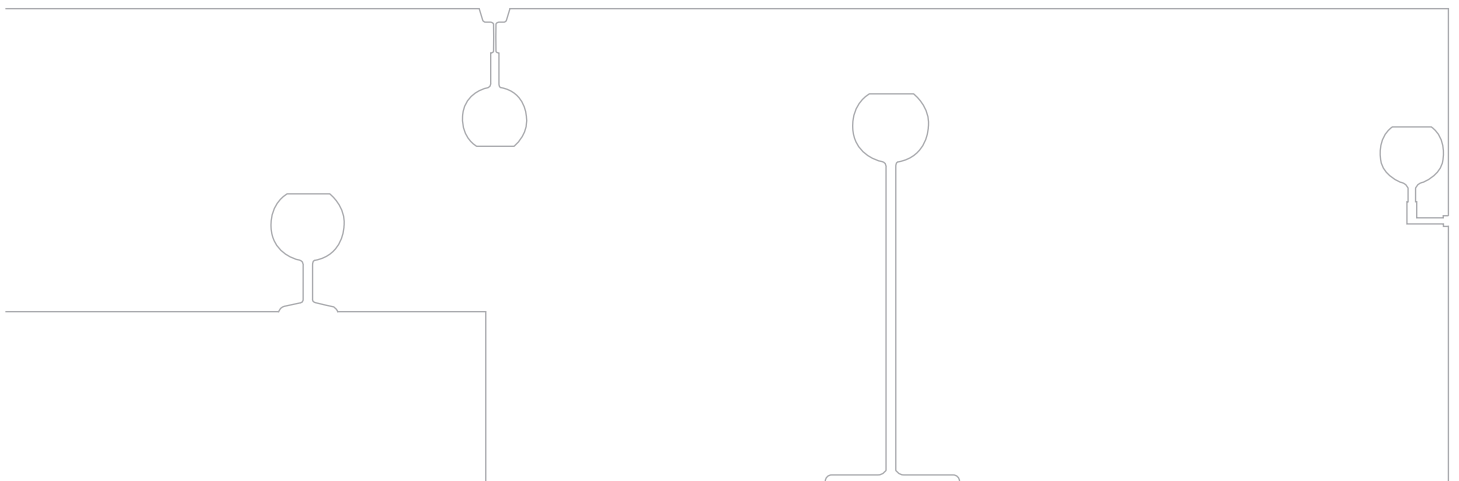





# Glo

## SUSPENSION

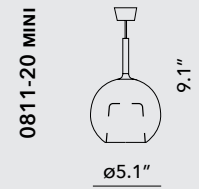
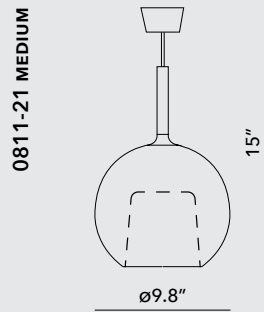
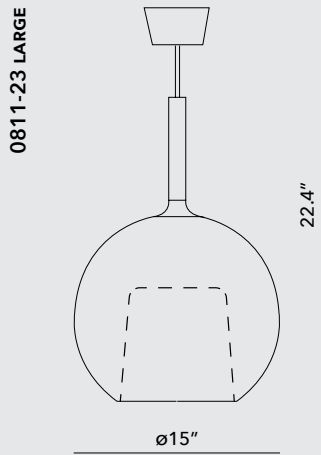

## LIGHT SOURCE

**0811-23**  
1x 10W - E26 LED / 1x max 100W - E26 Halo

**0811-21**  
1x 5W - E12 LED / 1x max 40W - E12 Halo

**0811-20**  
1x 3W - G9 LED / 1x max 28W - G9 Halo

## NOTE

Standard cable length 78.7"

## GLASS FINISHES



## STRUCTURE FINISHES

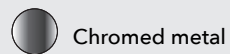

## CANOPY FINISHES

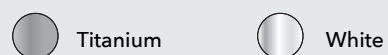



# Glo

## TABLE LAMP

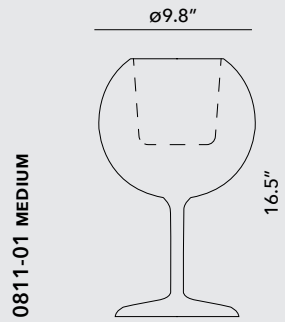
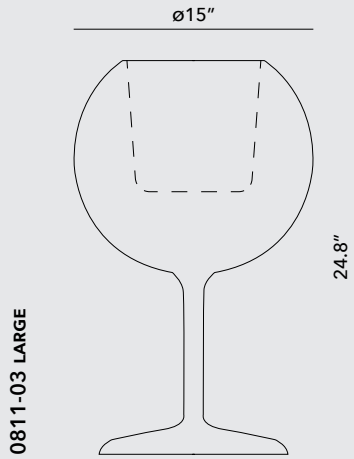

### LIGHT SOURCE

0811-03  
1x max 100W - E26 Halo / Dimmer

0811-01  
1x 5W - E12 LED / 1x max 40W - E12 Halo

0811-00  
1x 3W - G9 LED / 1x max 28W - G9 Halo

### GLASS FINISHES



### STRUCTURE FINISHES

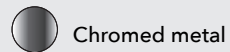



# Glo

## FLOOR AND WALL LAMP

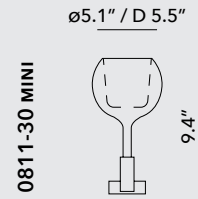
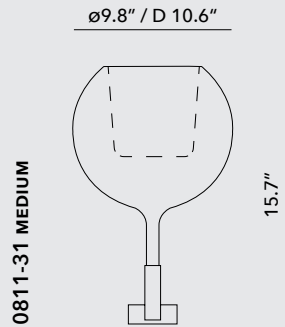
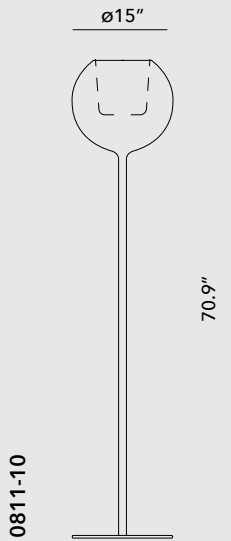

### LIGHT SOURCE - FLOOR LAMP

**0811-10**  
1x max 100W - E26 Halo / Dimmer

### LIGHT SOURCE- WALL LAMPS

**0811-31**  
1x 5W - E12 LED / 1x max 40W - E12 Halo

**0811-30**  
1x 3W - G9 LED / 1x max 28W - G9 Halo

### GLASS FINISHES



### STRUCTURE FINISHES

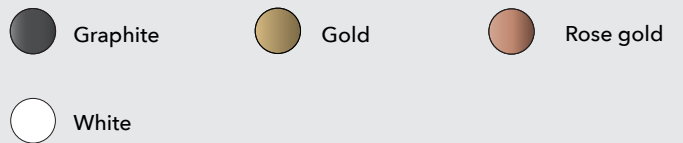







2005

# JEI JEI

Nicola Gallizia

Lamps with structure in nickel satin metal or bronze with modular large, medium and small arm shades in transparent borosilicate glass (fumé, amber or rose gold only on demand). Safety transformer in the upper steely canopy, with covering shade in borosilicate glass. Telescopic stem in satin steel.

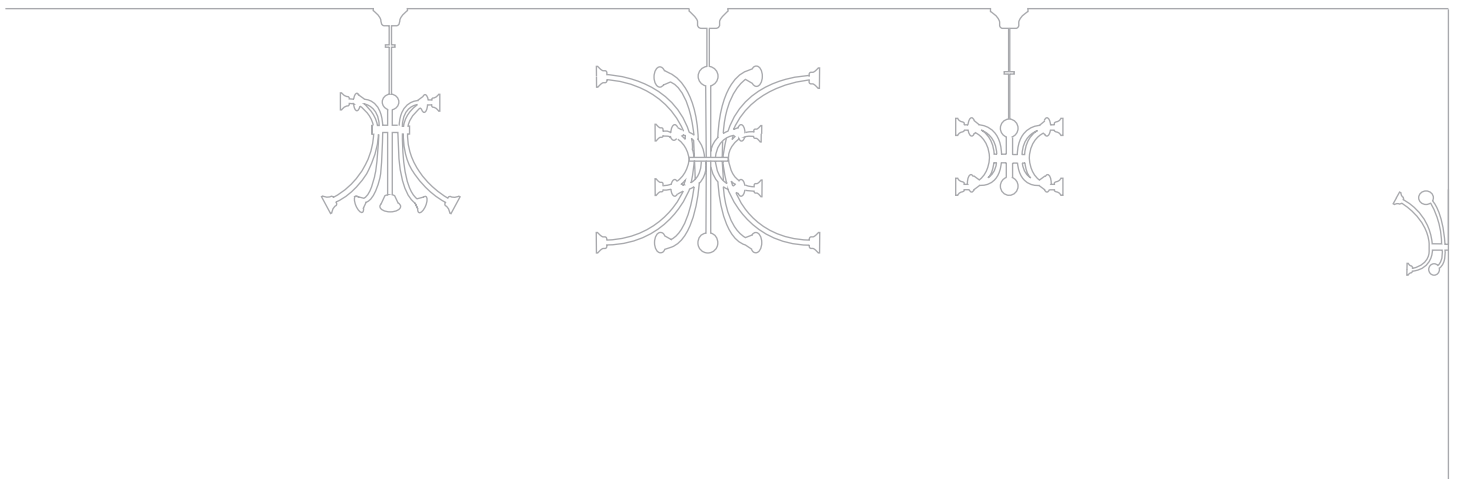



# Jeï Jeï

## SUSPENSION

0501-50 SUPERMAXI

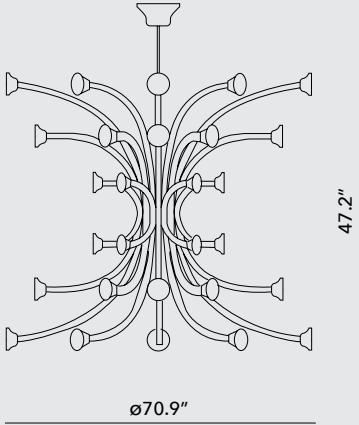

0501-24 MAXI

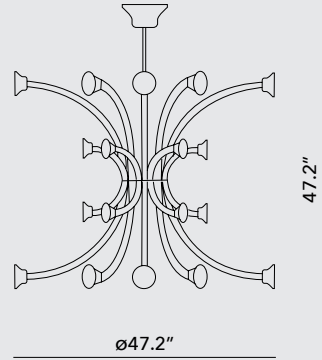

0501-22 MEDIUM

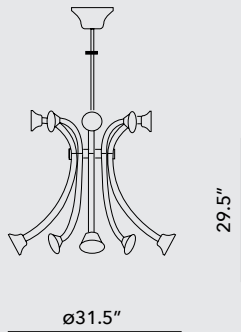

0501-22 MEDIUM

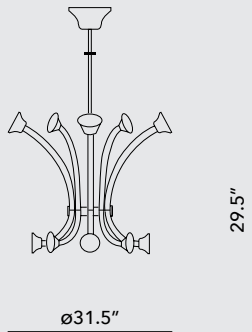

0501-22 MEDIUM

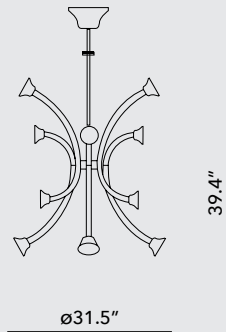

0501-21 SMALL

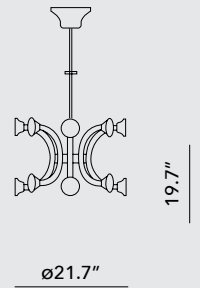

## LIGHT SOURCE

0501-50  
48x 2W -12V G4 LED

0501-24  
32x 2W -12V G4 LED

0501-22  
16x 2W -12V G4 LED

0501-21  
16x 2W -12V G4 LED

## GLASS FINISHES



## STRUCTURE FINISHES

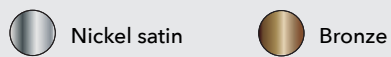





# Jeï Jeï

## WALL LAMP

---

0501-33 LARGE

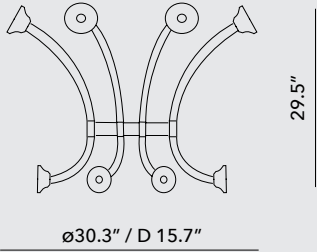

0501-31 SMALL

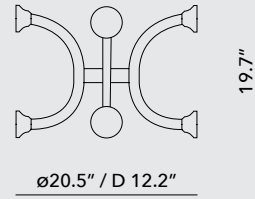

## LIGHT SOURCE

---

0501-33  
8x 2W -12V G4 LED

0501-31  
6x 2W -12V G4 LED

## GLASS FINISHES

---



## STRUCTURE FINISHES

---









2015

# JE SUIS

Carlo Colombo

Floor and table lamp with base in: oak, grey oak, stained anthracite wood  
or Carrara white marble.  
360° turning bicolor blown glass shade in white/silver.

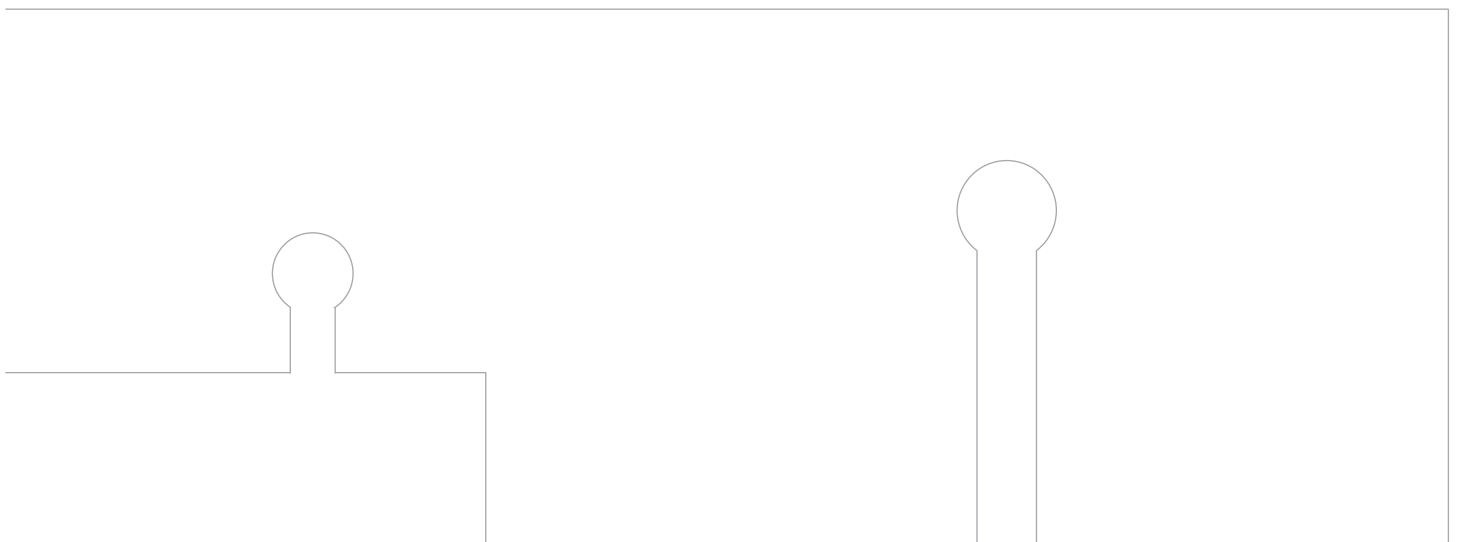





# Je Suis

## TABLE AND FLOOR LAMP

---

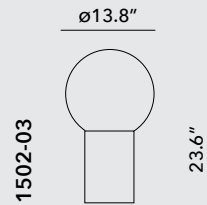
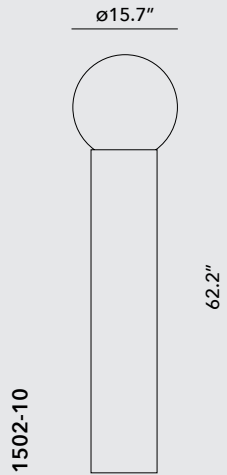

### LIGHT SOURCE

---

**1502-10**  
1x 17,5W - LED 3000 K\*

**1502-03**  
1x 17,5W - LED 3000 K\*

### GLASS FINISHES

---

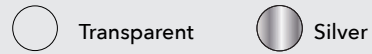

### STRUCTURE FINISHES

---





2015

# MAMI'

Umberto Asnago

Lamps with metal structure in matt graphite or bronze. Shade in white blown glass.

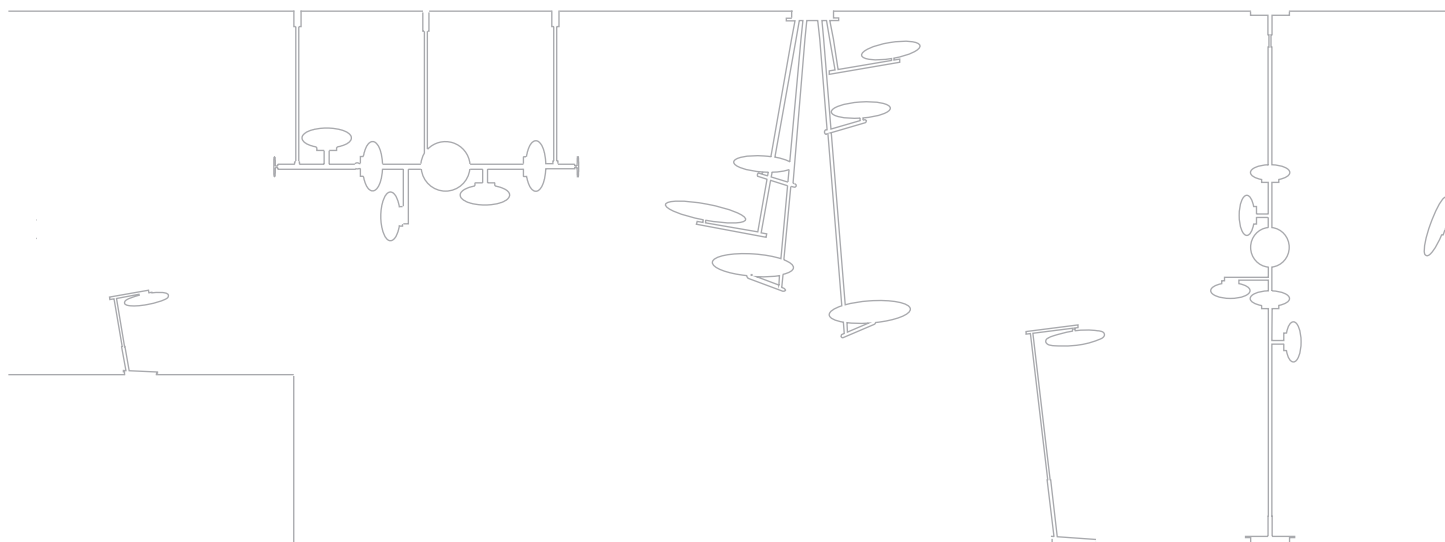





# Mami

## SUSPENSION

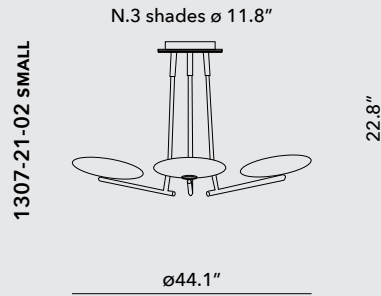
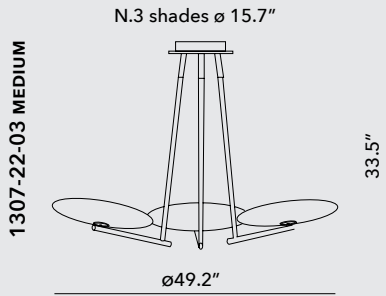
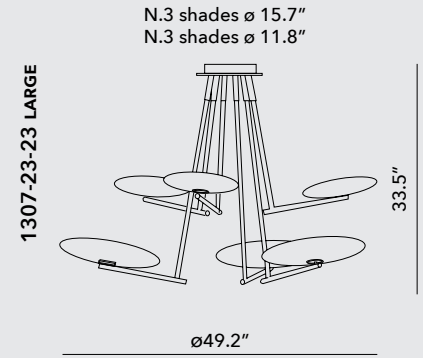
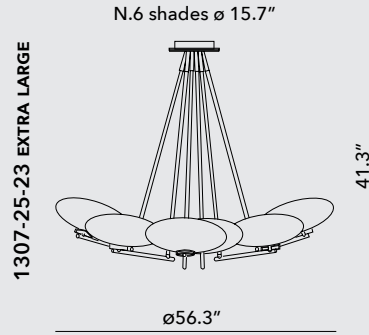

## LIGHT SOURCE

1307-24-23  
6x 10W LED 3000 K

1307-25-23  
6x 10W LED 3000 K

1307-23-23  
6x 10W LED 3000 K

1307-22-03  
3x 10W LED 3000 K

1307-21-02  
3x 10W LED 3000 K

## GLASS FINISHES



White

## STRUCTURE FINISHES



Bronze



Graphite



# Mami

## SUSPENSION

1307-26-02 LARGE

N.4 shades ø 11.8"

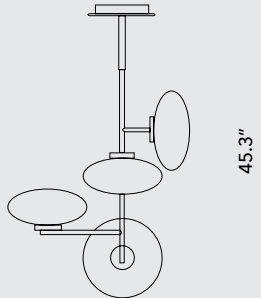

27.6"

45.3"

1307-26-01 SMALL

N.4 shades ø 7.9"

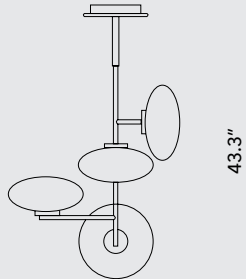

25.6"

43.3"

1307-26-04

N.2 shades ø 11.8"  
N.2 shades ø 7.9"

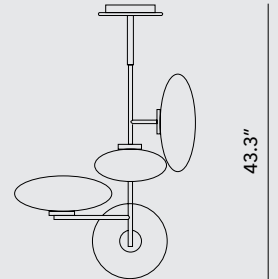

25.6"

43.3"

\* 1307-40 HORIZONTAL

N.6 shades ø 7.9"

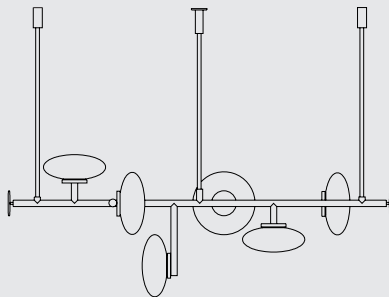

48.4"

18.9"

## LIGHT SOURCE

1307-26-02  
4x 10W LED 3000 K

1307-26-01  
4x 6W LED 3000 K

1307-26-04  
2x 10W LED 3000 K / 2x 6W LED 3000 K

1307-40  
6x 6W LED 3000 K

## NOTE \*

Standard cable length 78.7"

## GLASS FINISHES



White

## STRUCTURE FINISHES



Bronze



Graphite



# Mami

## TABLE AND FLOOR LAMP

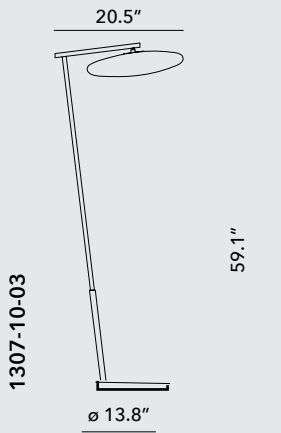
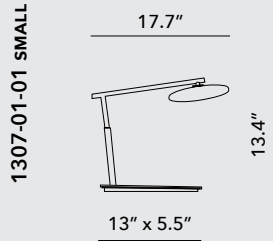
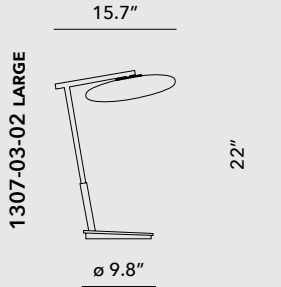

N.8 shades ø 7.9"

12.2"

ø 4.7"

1307-28-01 LARGE

106.3" - 118.1"

ø 12.2"

N.6 shades ø 7.9"

12.2"

ø 4.7"

1307-27-01 SMALL

98.4" - 110.2"

ø 12.2"

### LIGHT SOURCE- TABLE AND FLOOR LAMPS

1307-03-02  
10W LED 3000 K

1307-01-01  
6W LED 3000 K

1307-10-03  
10W LED 3000 K

### LIGHT SOURCE - FLOOR-TO-CEILING LAMPS

1307-28-01  
8x 6W LED 3000 K

1307-27-01  
6x 6W LED 3000 K

### GLASS FINISHES



White

### STRUCTURE FINISHES



Bronze



Graphite





# Mami

## WALL AND CEILING LAMP

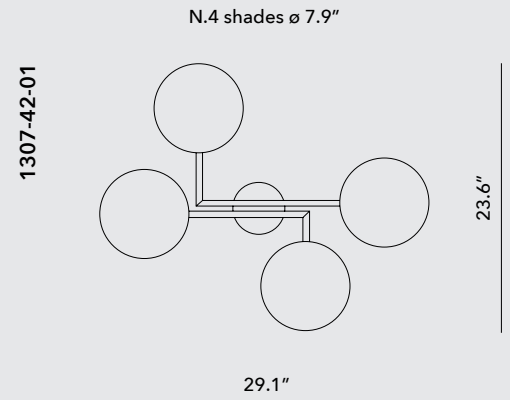
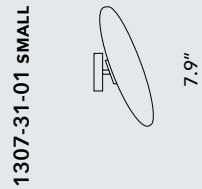
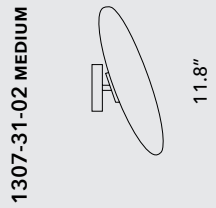
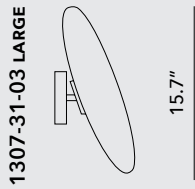
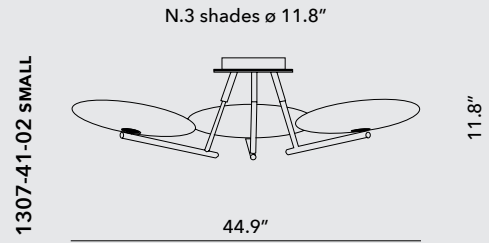
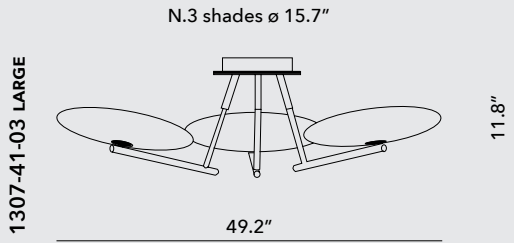

## LIGHT SOURCE - CEILING LAMPS

1307-41-03  
3x10W LED 3000 K

1307-41-02  
3x10W LED 3000 K

## LIGHT SOURCE - WALL LAMPS

1307-31-03  
10W LED 3000 K

1307-31-02  
10W LED 3000 K

1307-31-01  
6W LED 3000 K

1307-42-01  
4x 6W LED 3000 K

## GLASS FINISHES



## STRUCTURE FINISHES





2016

# MoM

Umberto Asnago

Collection of lamps in five shapes made in borosilicate glass:  
mat oxidized metallic finish in the colours blue avio, sage green, powder pink, sand, white.  
Glossy green, glossy blue, glossy violet.  
Canopy in white or black varnished metal.

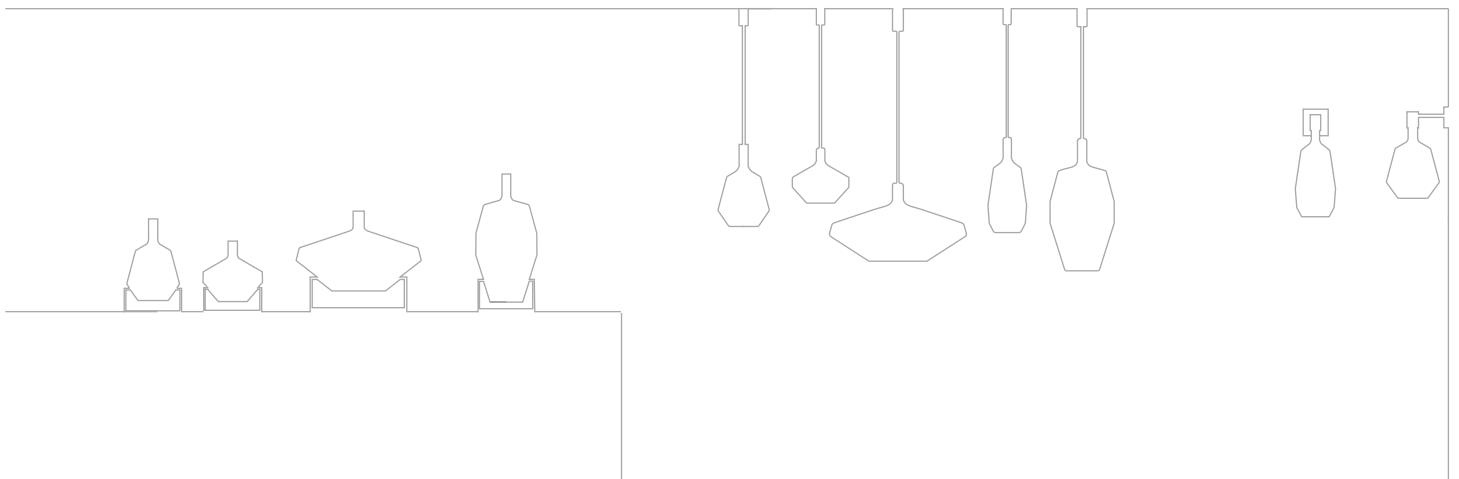





# MoM

## SUSPENSION

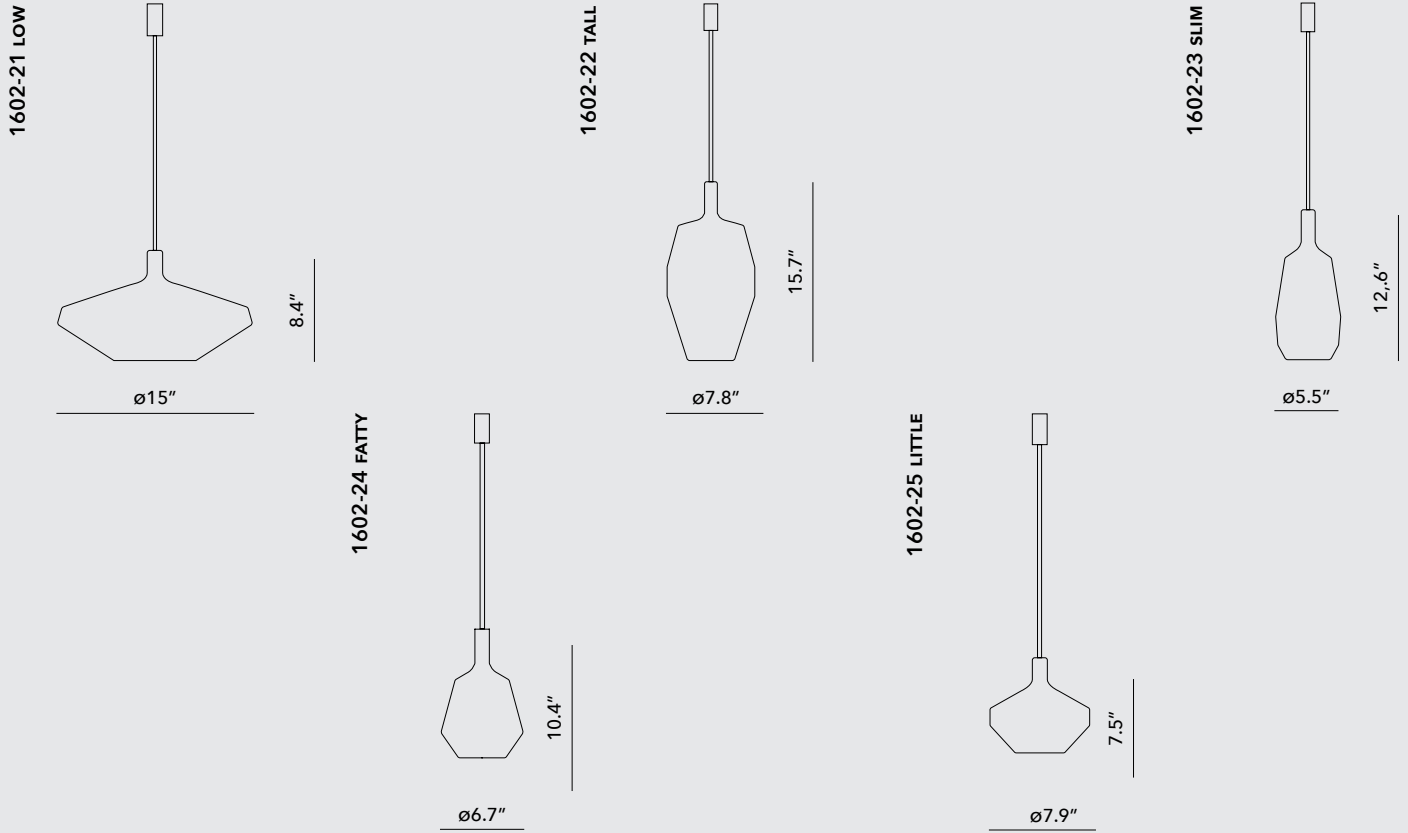

## LIGHT SOURCE

1602-21  
1x 10W - E26 LED / 1x max 60W - E26 Halo

1602-22  
1x 10W - E26 LED / 1x max 60W - E26 Halo

1602-23  
1x 10W - E26 LED / 1x max 60W - E26 Halo

1602-24  
1x 5W - E12 LED / 1x max 42W - E12 Halo

1602-25  
1x 5W - E12 LED / 1x max 42W - E12 Halo

## NOTE

Standard cable length 78.7"

## GLASS FINISHES



## STRUCTURE FINISHES

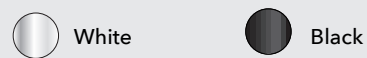



# MoM

## WALL AND TABLE LAMP



1602-33 SLIM  
ø5.5" / D 6.7"



1602-34 FATTY  
ø6.7" / D 6.7"

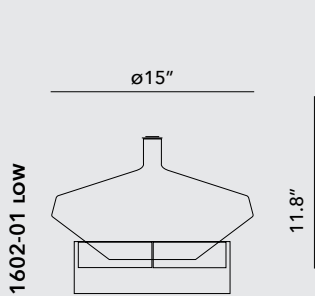

1602-01 LOW

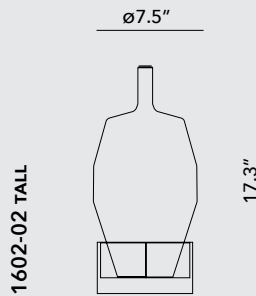

1602-02 TALL

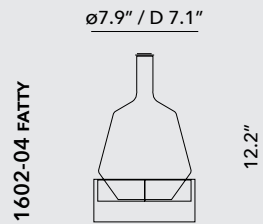

1602-04 FATTY

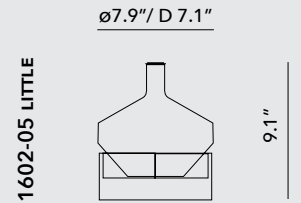

1602-05 LITTLE

### LIGHT SOURCE - TABLE LAMPS

**1602-01**  
1x 10W - E26 LED / 1x max 60W - E26 Halo

**1602-02**  
1x 10W - E26 LED / 1x max 60W - E26 Halo

**1602-04**  
1x 5W - E12 LED / 1x max 42W - E12 Halo

**1602-05**  
1x 5W - E12 LED / 1x max 42W - E12 Halo

### LIGHT SOURCE - WALL LAMPS

**1602-33**  
1x 10W - E26 LED / 1x max 60W - E26 Halo

**1602-34**  
1x 5W - E12 LED / 1x max 42W - E12 Halo

### GLASS FINISHES



### STRUCTURE FINISHES

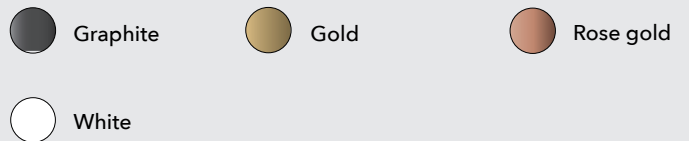



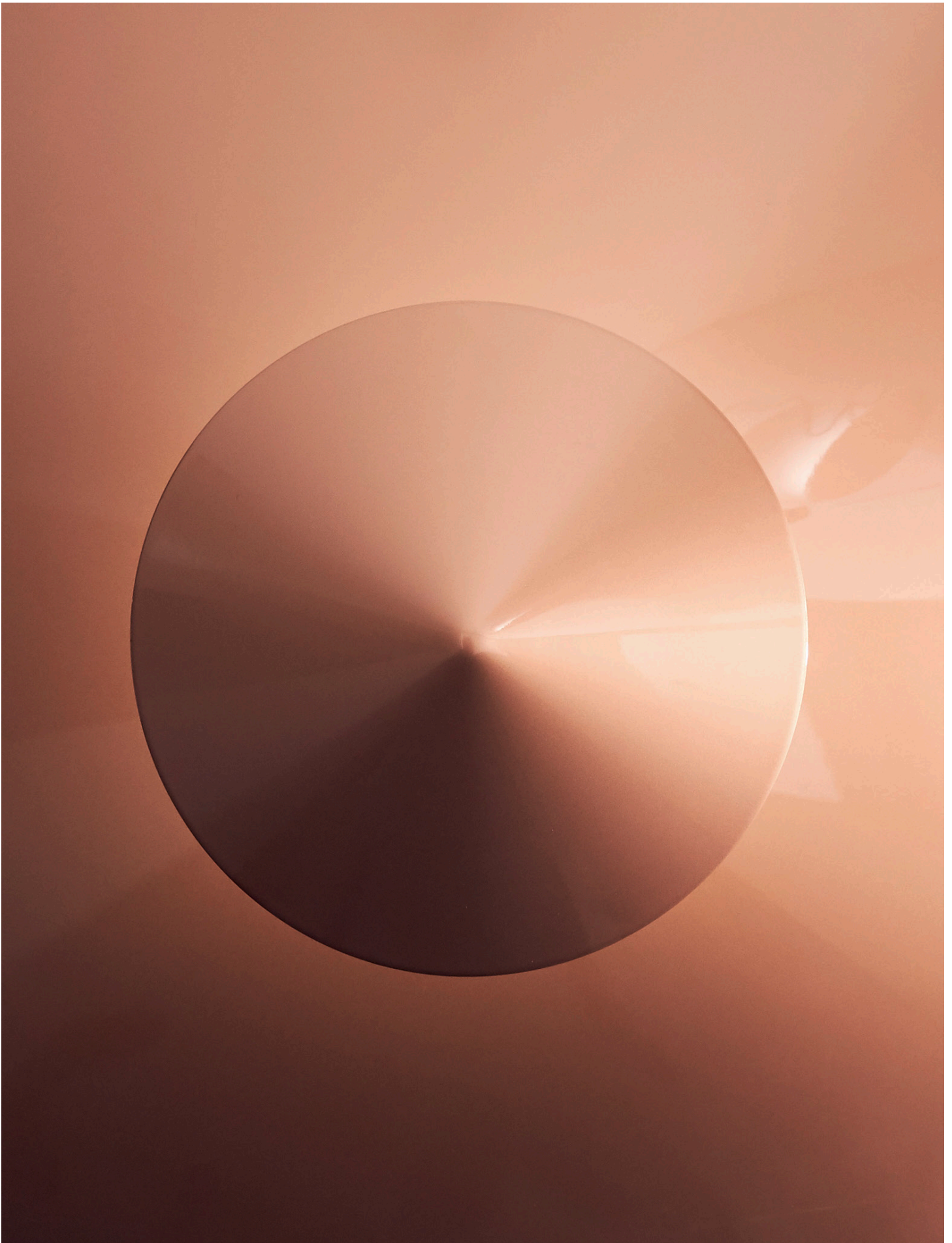

2017

# NARCISO

Nicola Gallizia

Lamps with metal structure in the matt finishes: gold, rose gold, graphite and white varnished. The small table lamp is portable, with rechargeable battery. The large table lamp is available in the portable/rechargeable version with Bluetooth audio speaker.

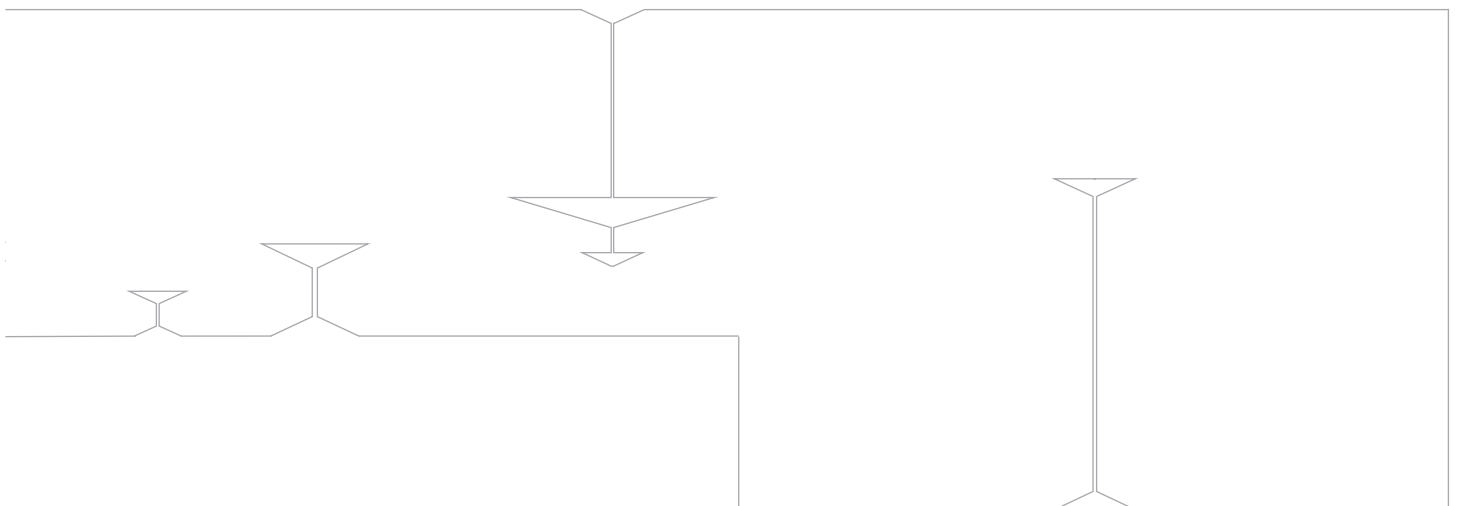



# Narciso

## SUSPENSION AND FLOOR LAMP

1710-20

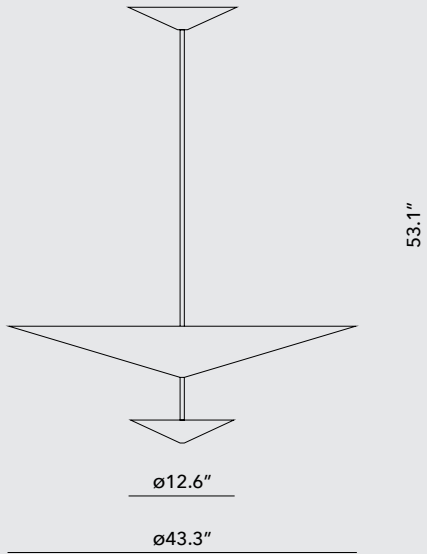

1710-10 FLOOR

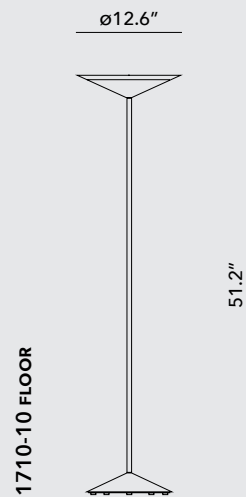

### LIGHT SOURCE - SUSPENSION

1710-20  
LED 3000K 14W 1500lm 25W 2800 lm (double lighting)

### LIGHT SOURCE - FLOOR LAMP

1710-10  
14W - LED 3000K 1500lm

### STRUCTURE FINISHES

Graphite

Gold

Rose gold

White





# Narciso

## TABLE LAMP

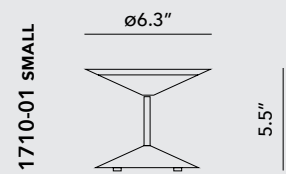
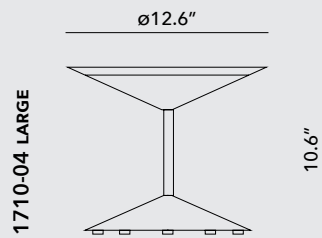
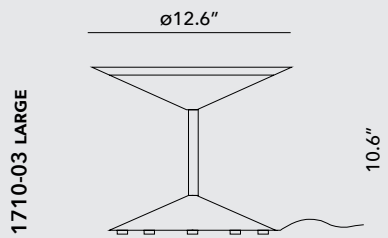

### LIGHT SOURCE

1710-03  
14W - LED 3000K 1500lm

1710-04  
8W - LED 3000K 1000lm

1710-01  
3W - LED 3000K 400lm

### STRUCTURE FINISHES









2003

# NEW CLASSIC

Umberto Asnago

Lamps with structure in opaque anthracite nickel and blown glass in the following colours: transparent, fumé, amber, amethyst, ruby, sapphire, olive-green. Interchangeable shades in different sizes in the fabrics of the collection, hand-made silk plissé excluded.

Complete top closure in plexiglas for table lamp only.

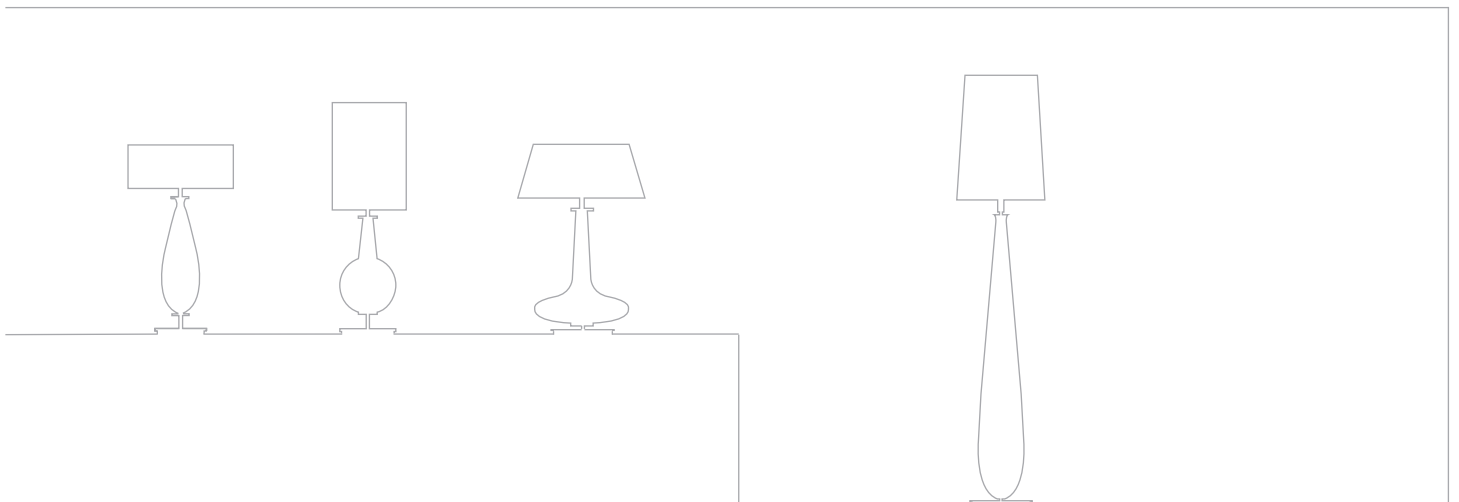





# New Classic

## TABLE LAMP

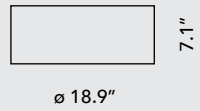
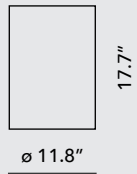
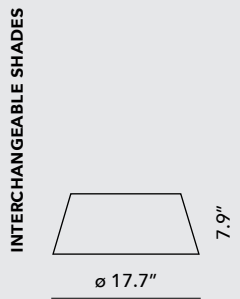
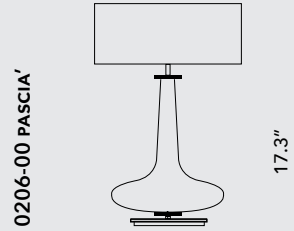
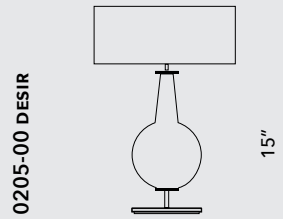
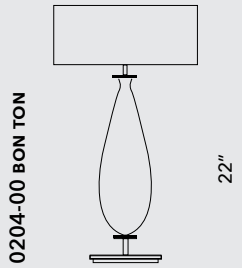

## LIGHT SOURCE

0204-00  
1x 10W - E26 LED / 1x max 100W - E26 Halo

0205-00  
1x 10W - E26 LED / 1x max 100W - E26 Halo

0206-00  
1x 10W - E26 LED / 1x max 100W - E26 Halo

## GLASS FINISHES



## STRUCTURE FINISHES

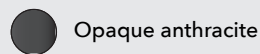

## SHADE FINISHES

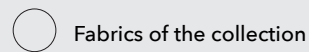





# New Classic

## FLOOR LAMP

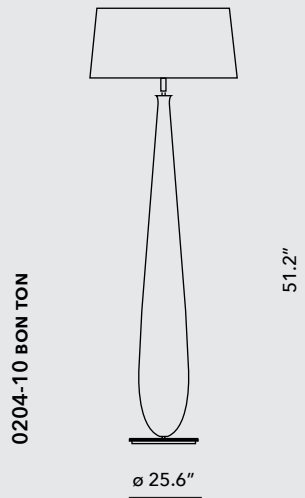

### INTERCHANGEABLE SHADES

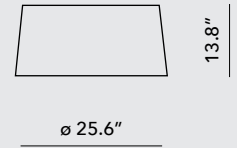
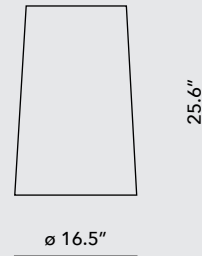

### LIGHT SOURCE

0204-10  
1x max 100W - E26 Halo

### GLASS FINISHES



### STRUCTURE FINISHES

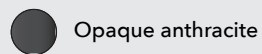

### SHADE FINISHES

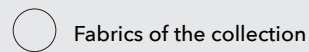





2017

# POP

Umberto Asnago

Adjustable wall lamp varnished metal in the finishes gold, rose gold, graphite, white and sand.



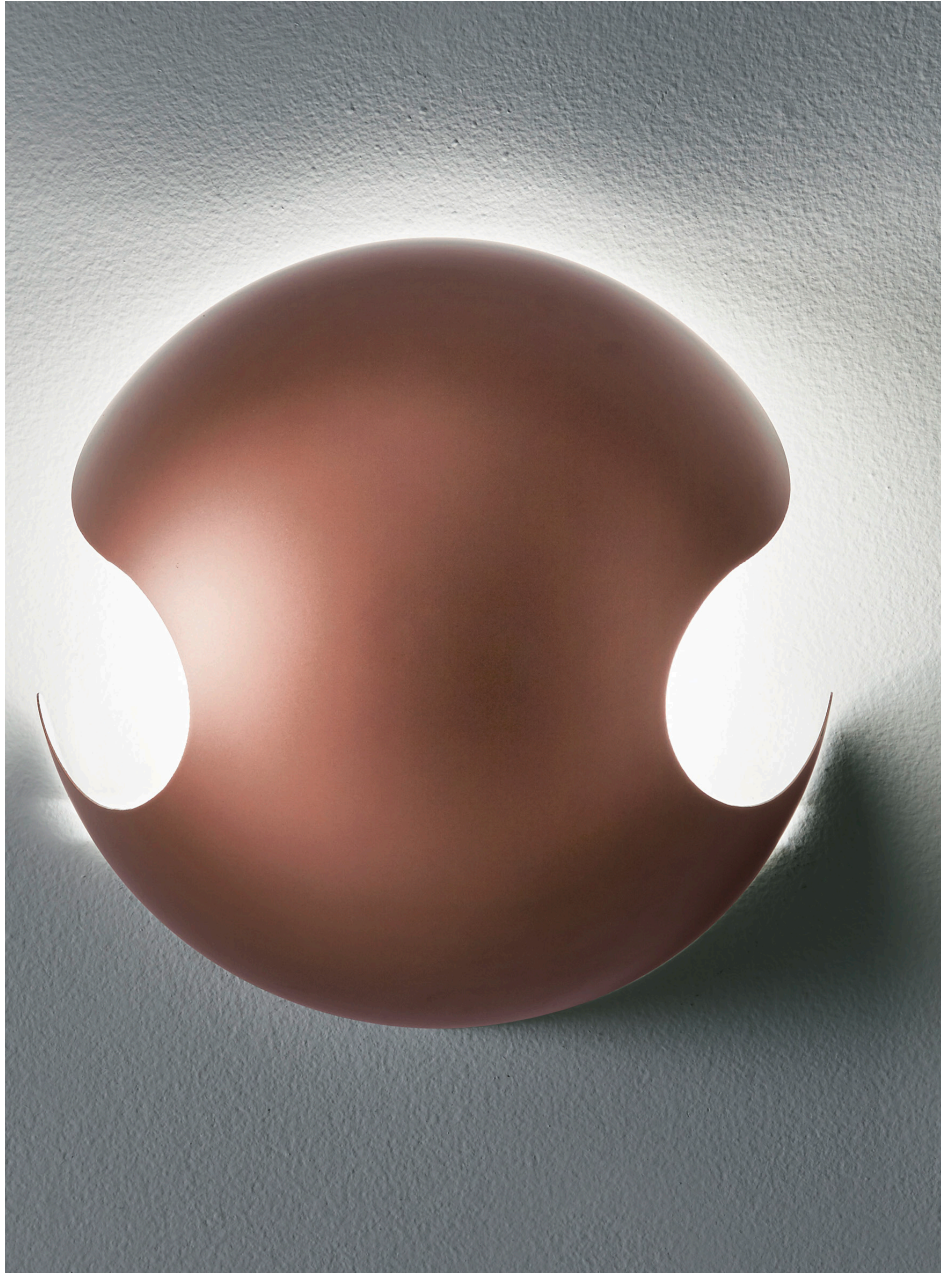



# Pop

## WALL LAMP

---

1705-30

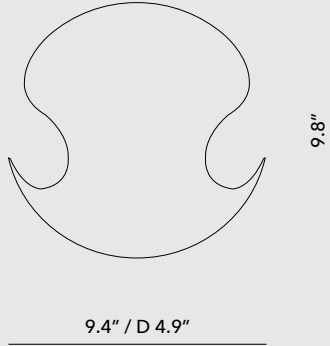

## LIGHT SOURCE

---

1705-30  
13W LED 3000K 1100 lm Dimm.TRIAC

## STRUCTURE FINISHES

---







2017

# STORM

Bartoli Design

Suspension made by a metal stick in the mat finishes: gold, rose gold and graphite.  
Available in three sizes: Large, Medium and Mini as single element or in cluster.  
Single canopy in the same finishes of the structure.

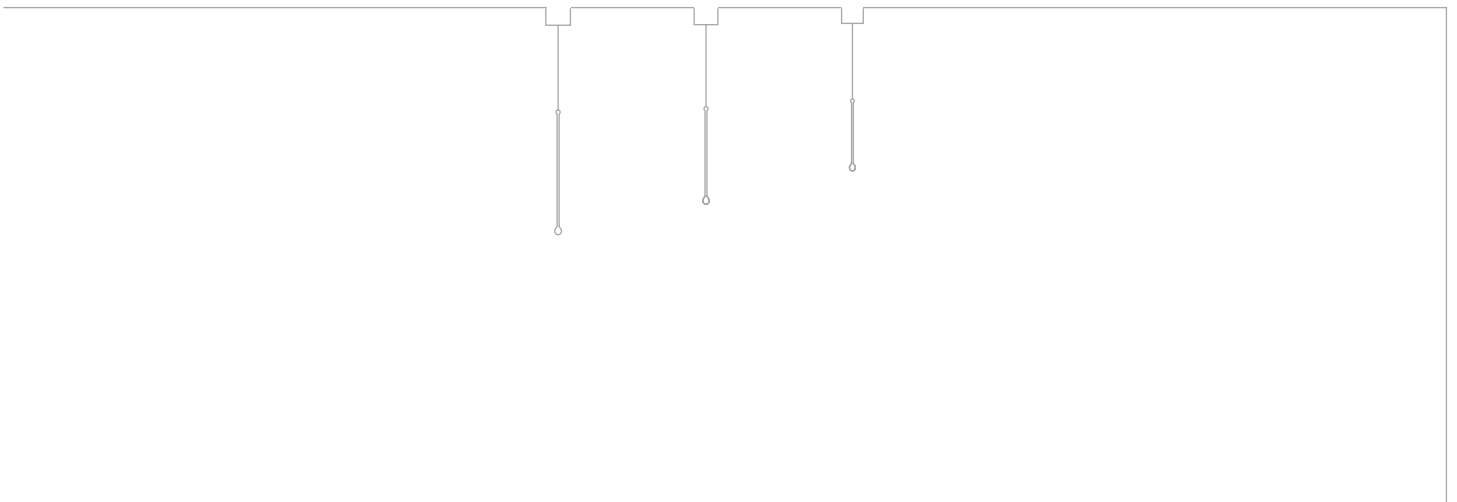



# Storm

## SUSPENSION

---

1704-23 LARGE



18.5"

1704-21 MEDIUM



16.5"

1704-20 MINI

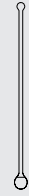

13"

## LIGHT SOURCE

---

1704-23  
4W LED 3000K 400 lm Dimmable on demand

1704-21  
4W LED 3000K 400 lm Dimmable on demand

1704-20  
4W LED 3000K 400 lm Dimmable on demand

## NOTE

---

Standard cable length 78.7"

## STRUCTURE FINISHES

---



Graphite



Gold



Rose gold





2015

# WONDER

Bartoli Design

Suspension with metal structure in the colours: mat gold, mat rose gold or mat graphite.  
Shade in transparent or fume borosilicate glass, supplied in three sizes: large, small and mini.  
Single canopy in the same finishes of the structure Available as single element or in cluster.

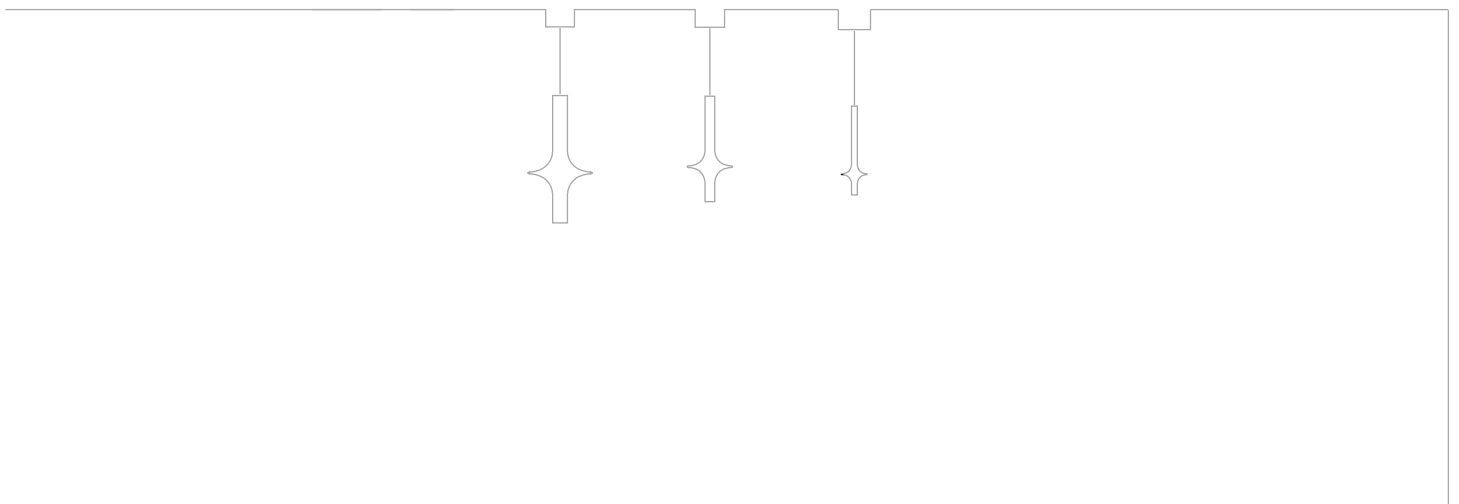





# Wonder

## SUSPENSION

---

1504-23 LARGE

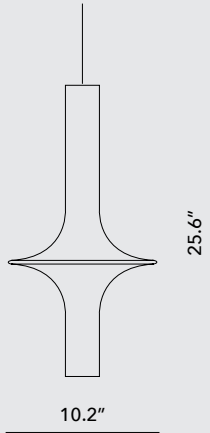

1504-21 MEDIUM

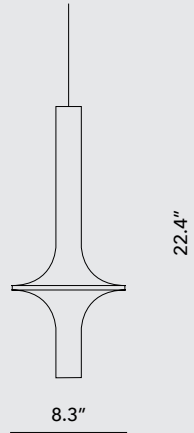

1504-20 MINI

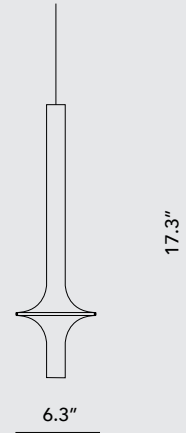

## LIGHT SOURCE

---

1504-23  
4W LED 3000K 400 lm Dimmable on demand

1504-21  
4W LED 3000K 400 lm Dimmable on demand

1504-20  
4W LED 3000K 400 lm Dimmable on demand

## GLASS FINISHES

---

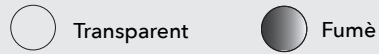

## STRUCTURE FINISHES

---



## NOTE

---

Standard cable length 78.7"





2015

# WOODY

Umberto Asnago

Suspension in solid walnut wood, in grey oak or in Carrara white marble.

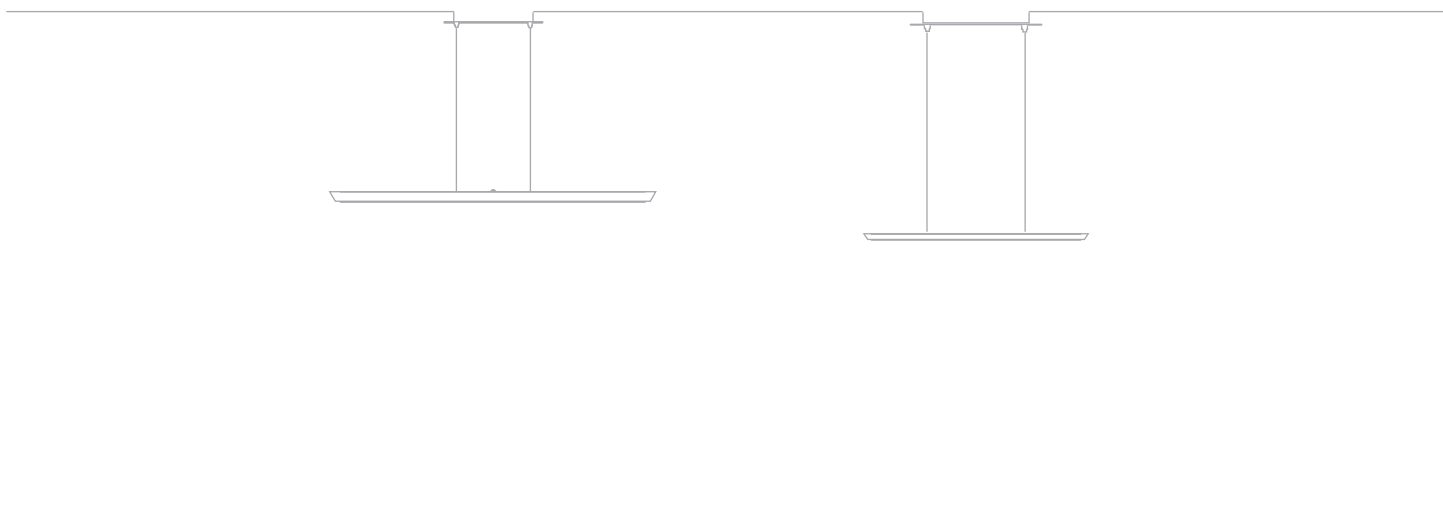



# Woody

## SUSPENSION

---

1406-23 LARGE

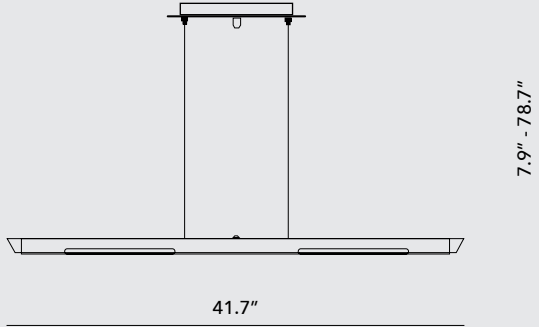

1406-21 SMALL

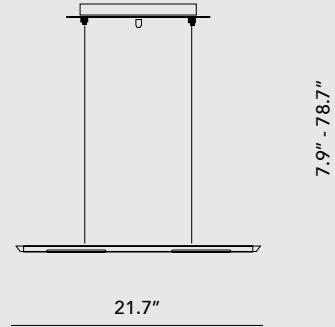

## LIGHT SOURCE

---

1406-23  
24,5W 24V LED 3000K

1406-21  
12W 24V LED 3000K

## NOTE

---

Standard cable length 78.7"

## STRUCTURE FINISHES

---



Walnut wood



Grey oak



White Carrara marble





# Plates & canopies

# A - Ceiling plates

## PLATES

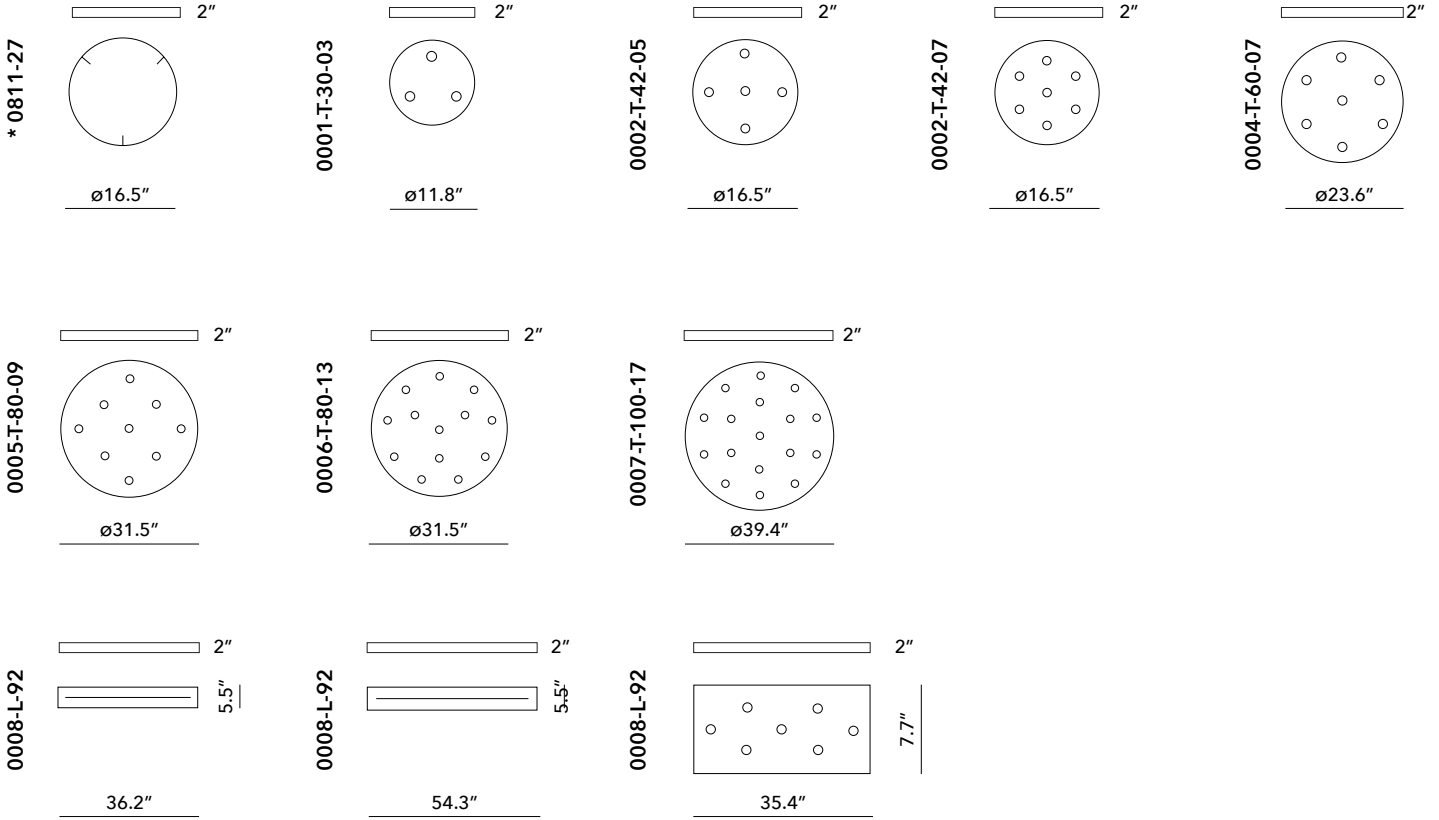

## NOTE

For Acorn, Glo and MoM only.

\* Not electrified plate

## FINISHES



# B - Ceiling plates

## PLATES

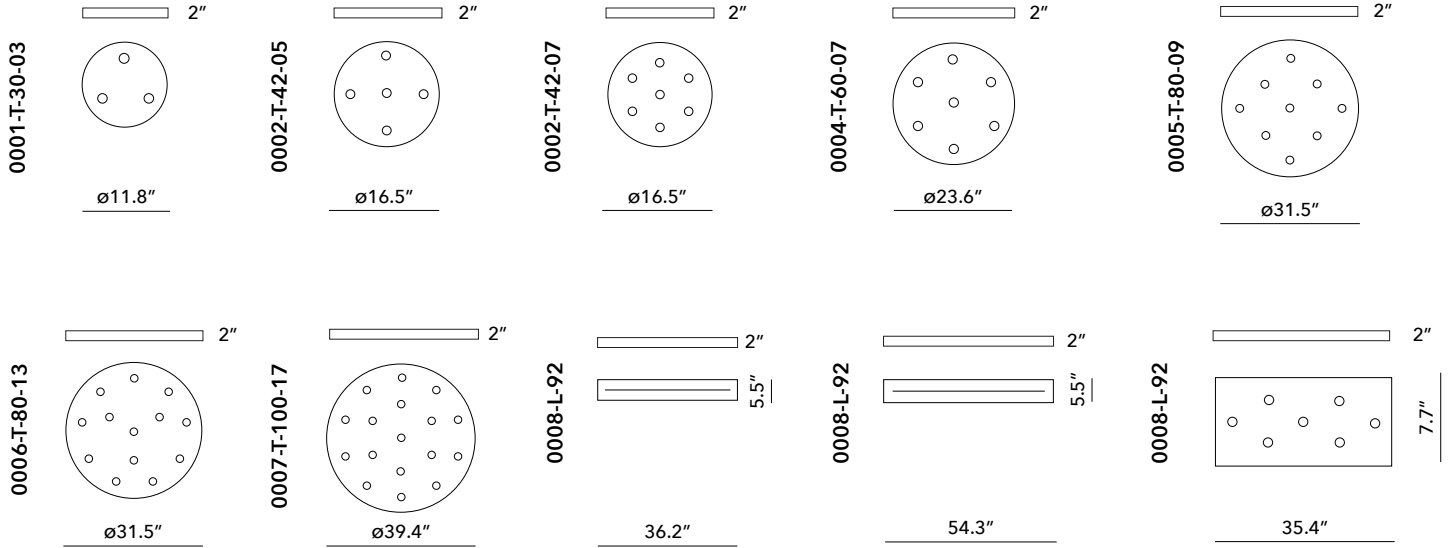

## NOTE

For Wonder and Storm only.

## FINISHES



Titanium



White



# C - Ceiling plates

## PLATES

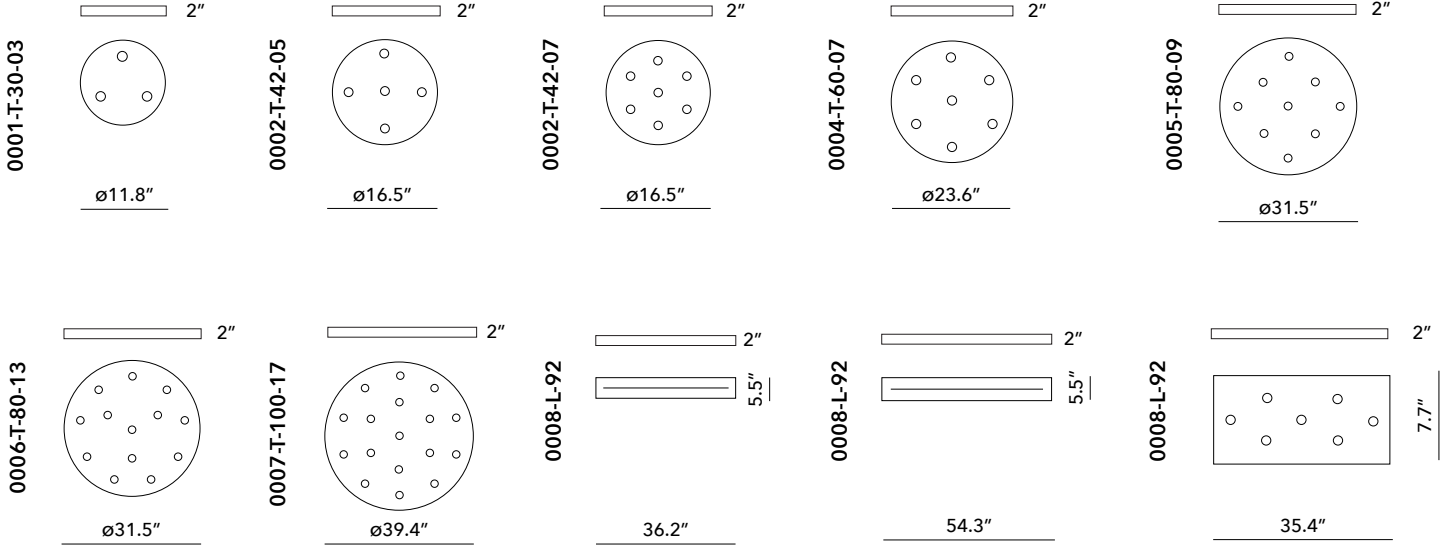

## NOTE

For Clip only.

## FINISHES







**PENTA Light USA Inc.** · New York, NY 10018  
(646) 688 3331 · Toll Free (844) 310 5598  
usa@pentalight.com · pentalight.com

Follow us on:









[pentalight.com](http://pentalight.com)  
[pentalightgroup.it](http://pentalightgroup.it)