



Artist: Maria Perello

revolutionizing the way art is illuminated

REVELITE®  
fine art lighting



Revelite brings art to life, evenly illuminating the surface of the artwork with beautiful color rendering accuracy.

Lighting Consultant: Staci Ruiz



# Art Revealed with Science

STANDARD PICTURE LIGHT



REVELITE TECHNOLOGY



Artist: Junn Roca

*"These lights revealed subtleties in paintings you just don't see with ordinary lights. I think we are seeing, truly for the first time, what the artist really wanted us to see."*

## **Pat Trenton, Ph.D.**

(nationally recognized art expert, curator, and writer)

The Revelite Art Light (AL) is a revolutionary picture light that is custom built and tuned at our facility in Southern California. This fixture evenly illuminates the entire surface of a painting using an extremely high color-rendering light source.

The uniformity and quality of light that this fixture emits is not achievable with the standard picture lights available today. The Revelite AL does not emit dangerous amounts of UV or heat.

All of these unprecedented attributes are embodied in an unobtrusive fixture profile that almost disappears when one views the art.

Every piece of fine art is unique and deserves to be brought to life with a premium lighting solution. The Revelite AL utilizes the latest LED and optical technology to provide exceptional illumination, allowing viewers to fully appreciate each detail of the artwork.

In appearance the Revelite AL appears elegant and simple, disguising a precise and highly-engineered product in a sleek, sophisticated, and compact package.

# A Revolutionary Art Light

custom tailored to provide even and accurate illumination



Artist: Junn Roca

## BECOMING THE SOLUTION

Revelite is the end result of an idea that was introduced to Cerno's founders by artist, art collector, and engineer Herb Seymour. Mr. Seymour searched for an art light that would render colors accurately and cast precisely the same amount of light across the entire piece of art. His search came up empty, so he turned to Cerno, who had the tools and the imagination to bring his idea to life. Through this partnership, Revelite was born, becoming the most sophisticated art light available on the market.

## MADE IN THE USA

In 2011, Revelite became the art and display lighting division of Cerno, a lighting company founded by three childhood friends from Laguna Beach, California. Today Revelite is producing a highly sophisticated art lighting system that utilizes the company's patented technology to deliver a product with unparalleled performance.



# What Makes Revelite Better than other art lights

## EVEN ILLUMINATION

This patented art light provides uniform light distribution over the entire width and height of an artwork. Standard art lights create a bright spot of light at the top of the art piece with minimal light reaching the bottom. Revelite's high degree of light control brings focus to the entire canvas and minimizes spill light around the artwork. To achieve this uniformity, each art light is custom built and factory calibrated for an artwork's specific dimensions, resulting in a bespoke product.

## MINIMAL SCALE

Revelite's discreet form virtually disappears against the frame or wall and pairs well with various styles of art including impressionism, modernism, contemporary, photography, and works behind glass. Select the Revelite with the traditional round profile or the modern low profile to suit your artwork and design aesthetic.

## ART SAFE

Revelite LED technology is art safe, providing a safer alternative to traditional sources that emit excessive and damaging UV and heat.

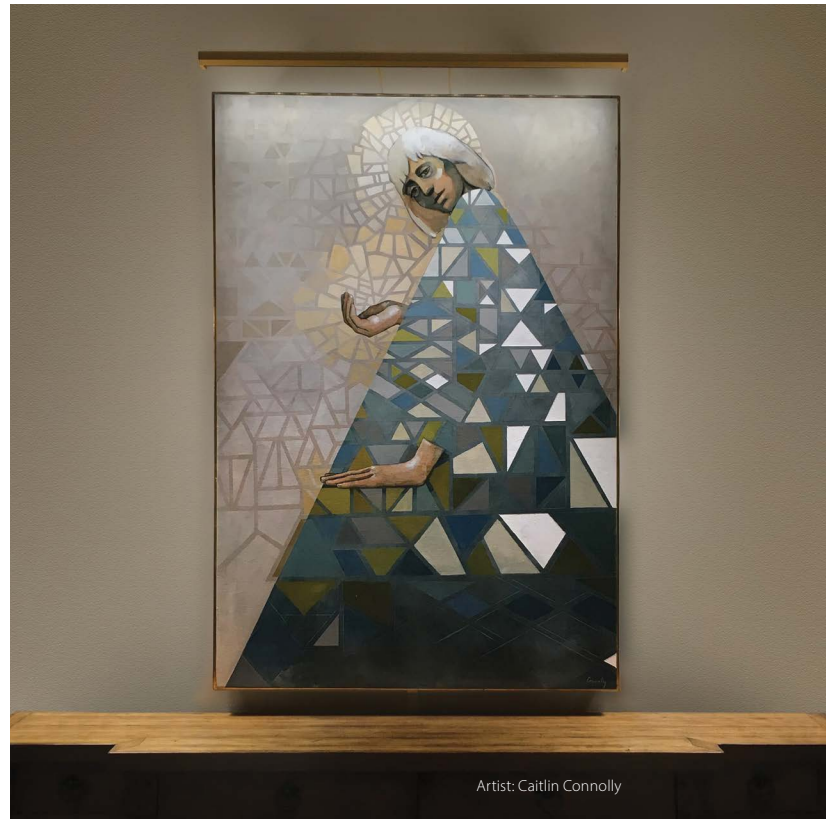

Artist: Caitlin Connolly



Artist: Wolfgang Bloch

## COLOR ACCURACY

The quality of a light source significantly impacts the colors that we see. The Revelite AL incorporates LEDs with a high Coloring Rendering Index (CRI) and R9 Value to accurately reflect the artist's color palette. The 3000K color temperature light source remains constant through the dimming curve and keeps whites natural and crisp, ideal for both old world masters and contemporary pieces.

## LOW MAINTENANCE

The Revelite is virtually maintenance free, with a lifetime rating of over 50,000 hours.

## MULTIPURPOSE

Although originally designed for illuminating works of art, the Revelite AL is also an ideal light for illuminating feature walls, bookshelves, displays, menu boards, and anywhere a precise, vertical wash of light is required.

# Revelite Standard Mount Art Light



Artist: Stephen Fox

The **Standard Mount Art Light** can mount to the back of the frame or the wall behind the art. The mount allows you to adjust the height of the fixture.

The standard mount can be hardwired or plugged into an outlet. Please note that the plug-in version comes with an inline AC adapter.

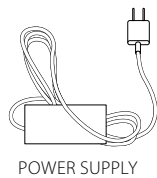
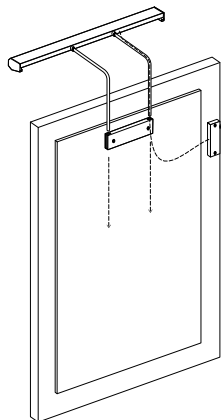

POWER SUPPLY



STANDARD MOUNT LOW PROFILE



STANDARD MOUNT ROUND PROFILE

## STANDARD FINISHES

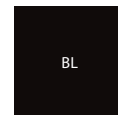

Black

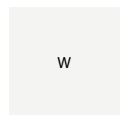

White



Gold

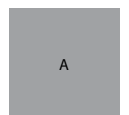

Brushed Aluminum

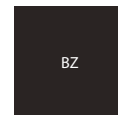

Oil Rubbed Bronze

## PREMIUM FINISHES



Satin Nickel



Brushed Brass



# Revelite Direct Wire Wall Mount Art Light

The **Direct Wire Wall Mount Art Light** attaches to the wall above an art piece. This option requires mounting the fixture to a junction box properly sized to house the appropriate hardwire power supply.

The canopy comes in two sizes:

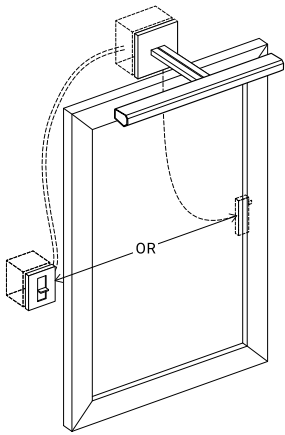

**Square**  
4.50" H x 4.50" W for attaching to a 4" square junction box with a 3" round plastic ring or an octagonal box.

**Rectangular**  
3.00" H x 4.50" W for attaching to a single gang switch box mounted horizontally.



**DIRECT MOUNT LOW PROFILE SQUARE CANOPY**



**DIRECT MOUNT ROUND PROFILE RECTANGULAR CANOPY**

## STANDARD FINISHES

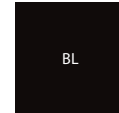

Black



White



Gold

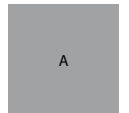

Brushed Aluminum

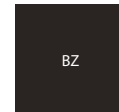

Oil Rubbed Bronze

## PREMIUM FINISHES



Satin Nickel



Brushed Brass

**Disclaimer:** Revelite fixtures specified for artwork with a width greater than 60" will ship as two separate fixtures joined with a connector bracket. The horizontal light distribution may appear disrupted beneath the point at which the two fixtures are joined.



Artist: Roy Nachum | Lighting Consultant: Staci Ruiz

# Technical Specifications

## THE RIGHT LIGHT FOR YOUR ART

**AL1:** single row of LEDs: The Revelite AL1 is optimized for paintings less than 16" tall.

**AL2:** two rows of LEDs: The Revelite AL2 is optimized for paintings from 16" to 36" tall, capable of vertical performance up to 60". (Vertical wash will taper after 36")

All fixtures are available in nominal widths from 7" to 60". We suggest measuring the width of the desired illuminated area and rounding down to the next available size.

Two or more fixtures can be installed side by side for canvas widths over 60". A second fixture can be added to the bottom of a canvas when illuminating very tall areas.

## TWO HOOD SHAPES ARE AVAILABLE AS AN AESTHETIC OPTION BOTH OFFER IDENTICAL PERFORMANCE

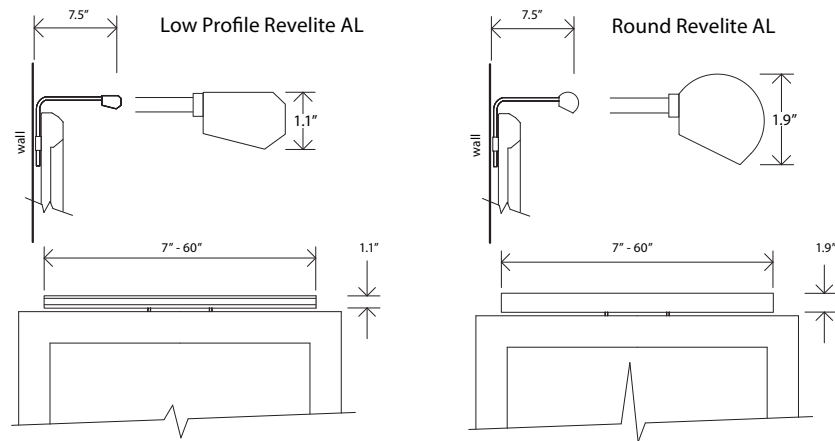

## ILLUMINATION AREA AND CALIBRATION

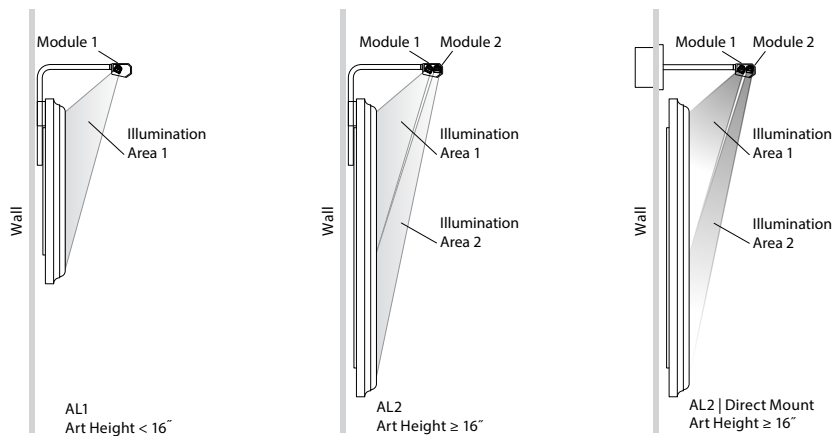

The width of the illumination area is controlled by the width of the fixture. The height of the illumination area is controlled by calibrating the fixture to the specific canvas height.

Calibrating the fixture involves adjusting the angles of the LED modules and their relative brightness to achieve consistent vertical illumination. Lights are calibrated at the factory and also field adjustable.

**Disclaimer:** Reflective frames with complex geometry may experience spotting from LED source.

## COLOR SPECTRUM

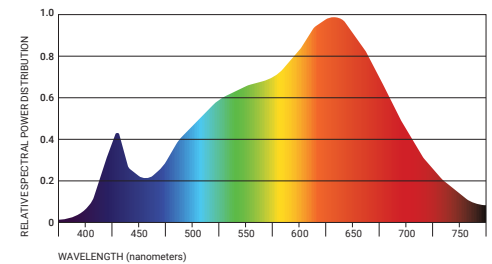

Color Temperature: 3000K

CRI: 90+, R9 = 83

Lifespan: 50,000+ hours

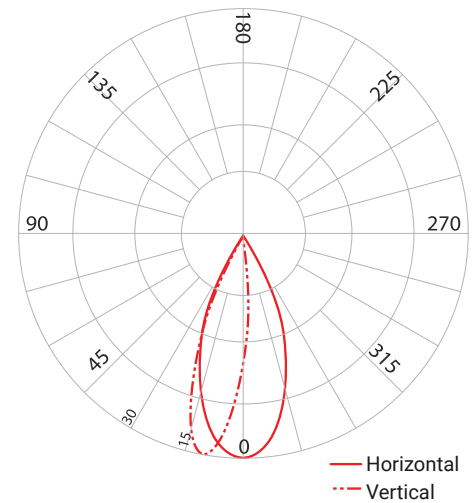

## PHOTOMETRICS

The photometric polar diagram seen is a Revelite AL2 calibrated for a 24" tall canvas.

Max values and distribution of luminous intensity will vary for different size lights and for calibrations of different canvas heights.

The Max Intensity = 325 Candela located at Horizontal Angle = 0° located at Vertical Angle = 0°



CLASS 2 LOW VOLTAGE  
3 YEAR WARRANTY  
US PATENT # 7,070,293 AND 9,134,004  
INTERNATIONAL PATENTS PENDING  
MADE IN THE USA



# Power and Wiring

## POWER CONSUMPTION

The max power consumption of the Revelite AL varies between models. The actual power consumption will typically be less than what is stated based on how the fixture is calibrated for the specific piece of art.

	AL1	AL2
MAX POWER CONSUMPTION (WATTS/FT)	5	10
MAX SOURCE LIGHT OUTPUT (LUMENS/FT)	470	940

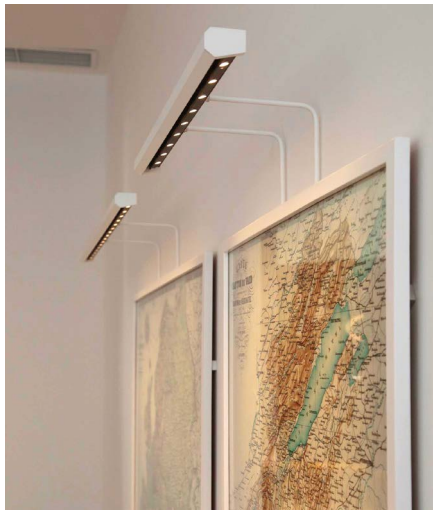

## DIMMING

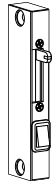

Revelite AL is 0-10V dimmable and comes with a dimmer switch that can be attached out of sight on the rear of the frame. It is also compatible with most third party 0-10V dimmers.

Dimming Range: 10% to 100%.

< 1V = off | 1V = 10% | 10V = 100%

Output increases linearly between 1V and 10V. When being used with a current sinking dimmer, each Revelite AL fixture sources <10mA.

## POWER SOURCE

The Revelite AL is a low voltage fixture and requires a low voltage DC power supply. Several varieties of power supplies are offered and should be selected based on the size of the fixture and the installation conditions. If you wish to power multiple Revelite AL fixtures with a single power supply, make sure the sum of the power drawn by each fixture does not exceed the maximum power rating for the particular power supply.

Plug-in power supplies are included with the price of the fixture. Hardwire power supplies are available at an additional cost. Power supplies must be connected to an undimmed power source.

TYPE	MAX POWER	INPUT VOLTAGE	DIMENSIONS	MAX AL1 LENGTH	MAX AL2 LENGTH	PART NUMBER
plug-in	24w	100-240 VAC	3.88" x 1.75" x 1.25"	46"	24"	52-24V1AB
plug-in	60w	100-240 VAC	4.44" x 2" x 1.25"	130"	65"	52-24V2.5AB
hardwire	36w	100-277 VAC	2.76" x 1.57" x 1.06"	77"	38"	52-RSLP035-24
hardwire	72w	100-277 VAC	2.76" x 2.24" x 1.06"	155"	77"	52-RSLP070-24
high power remote	96w	100-277 VAC	12.32" x 2.44" x 1.54"	207"	103"	52-LDS96W24V NDRE-0020

## TAPERWIRE

The option of this paper-thin flat wire is available to offer a discreet power solution without having to go through the process of installing a junction box.



Installation is as simple as peeling off the back and sticking the flat Taperwire onto a wall from the floor to behind a frame.

Taperwire can be painted over to create an inconspicuous connection between a Revelite and its power supply.

Please inquire for custom lengths.

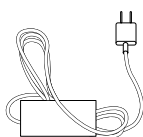

## MICROWIRE

Each Revelite fixture comes with 6' of Microwire, a slim wire to deliver low voltage from the power supply to the Revelite fixture. It can be discreetly run from a remote power supply to the fixture in an unobtrusive manner.

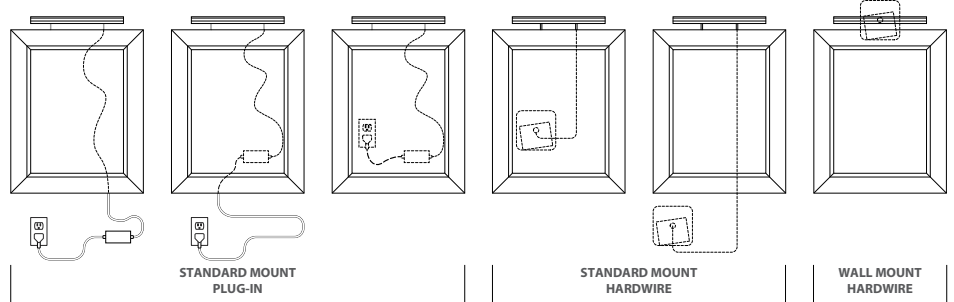

## PLUG-IN OPTIONS

Ready to plug directly into a standard AC outlet. Only available with Standard Mount option. Each light also comes with 6' of white Microwire to extend the distance from the light to the wall outlet.

## HARDWIRE OPTIONS

Allows the power supply to be placed inside a recessed junction box and will require the help of an electrician.

# Revelite Art Light Order Form

NAME OF ARTWORK \_\_\_\_\_ CANVAS HEIGHT \_\_\_\_\_ CANVAS WIDTH \_\_\_\_\_ (canvas or desired illuminated area)

CLIENT/PROJECT \_\_\_\_\_ DATE \_\_\_\_\_

REVELITE AL PART #AL

--	--	--	--	--	--

## CANVAS HEIGHT



Height less than 16"  
Height 16" or greater

1  
2

## CANVAS WIDTH

### NOMINAL WIDTHS

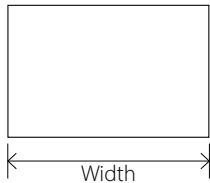

7 10 12 14 17 19 22 24 26 29 31 34 36 38 41 43 46 48 50 53 55 58 60  
Choose the nominal width closest to the actual width of the canvas (or desired illuminated area).  
If the actual width is between two nominal widths, we recommend choosing the smaller nominal width.  
If the canvas is over 60" wide, two or more fixtures will be used side by side and joined by a bracket.  
The horizontal light distribution may appear disrupted beneath the point at which the two fixtures are joined. Leave this section blank and we will select the appropriate fixtures for you.  
Be sure that the "Width of Canvas" section is filled out at the top of this form.)

## REVELITE AL FINISHES

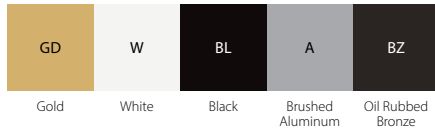

STANDARD



PREMIUM

GD  
W  
BL  
A  
BZ  
BB  
SN

## PROFILE SHAPES

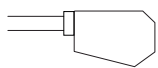

Low Profile Revelite AL

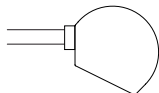

Round Revelite AL

Low Profile  
Round

L  
R

## MOUNTING METHOD

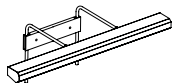

**Standard Mount**  
The standard mount can be attached to the frame of the painting or to the wall.

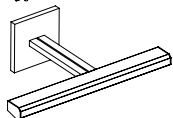

**Direct Wire Wall Mount**  
The direct wire wall mount attaches directly to the J-box\*

Standard Mounting  
Direct Wire Wall Mount Square Canopy  
Direct Wire Wall Mount Rectangle Canopy

S  
D  
C

\*The direct wire wall mount is available in two different sized bases:  
Square: 4.5"W x 4.5"H | Rectangle: 4.5"W x 3"H  
The rectangular option must use a single gang J-box mounted horizontally.  
A plug-in power supply is not available for the Direct Wire Wall Mount options.

## POWER

The Revelite AL is a low voltage fixture and must be used with an approved power supply.

Plug-In (Only Available with Standard Mount)  
Hardwired  
No Power Supply\*

P  
H  
N

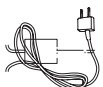

Plug-In

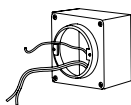

Hardwired

\*Only choose the "No Power Supply" option if you have contacted the manufacturer and discussed a custom power supply option.



# Revelite Easel Light



Designed and built in California  
by creatives for creatives

Artist: Jeff Sewell



Revelite's Easel Light (EL) provides an opportunity for a consistent lighting environment as a painting transitions from a blank canvas to the wall of a collector's home. Staying true to our company's promise in delivering superior results, the Revelite EL comes with the same exceptional illuminating features as the Art Light.

The Easel Light is available in three standard widths: 12", 24" and 36".



REVELITE®  
fine art lighting